

Swash Plate Type Axial Piston Motor **M7V / M7X Series**

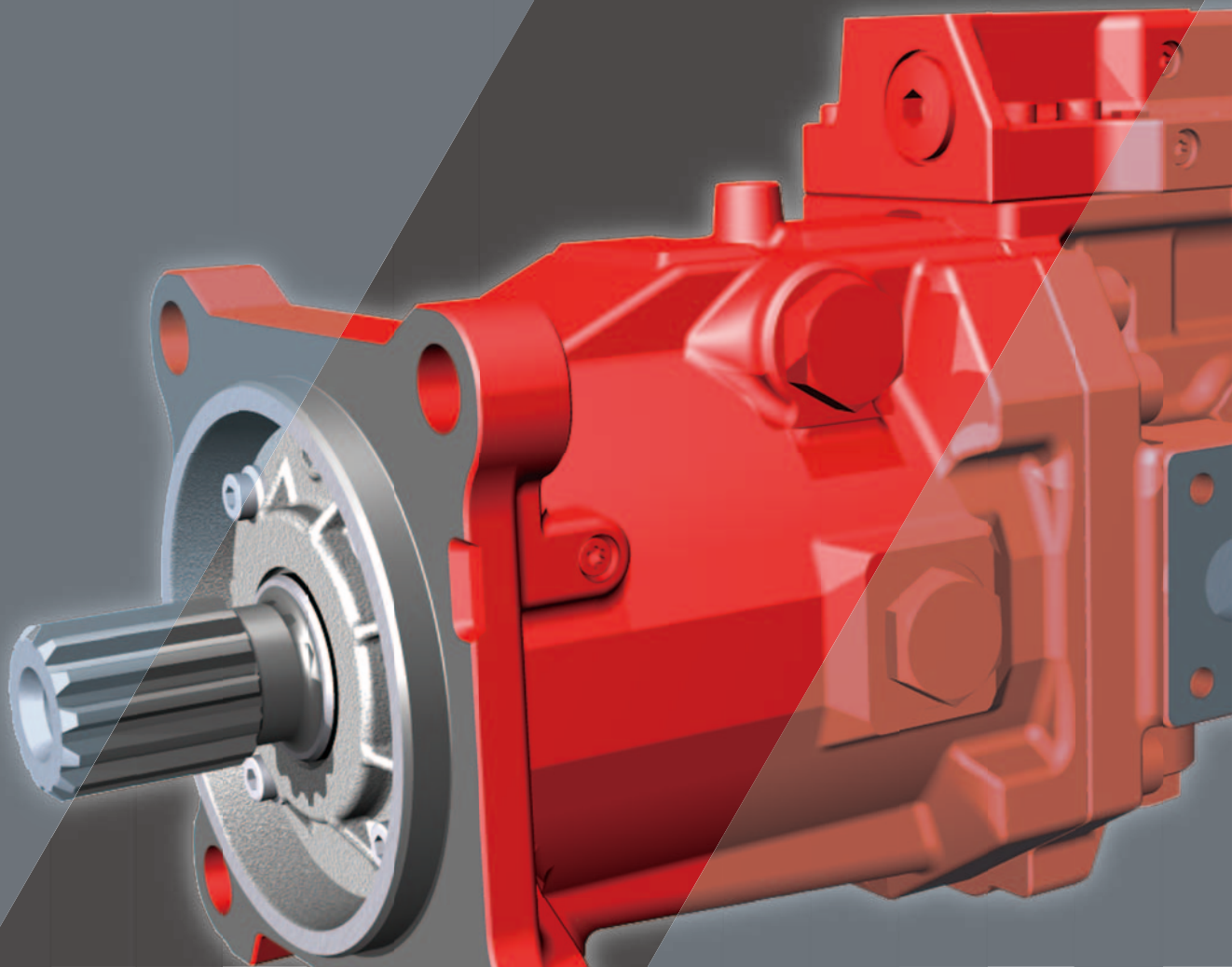

CONTENTS

I . Applications / Product Usage	2
II . Safety Precautions	3
III . Handling Precautions	4
IV . Conversion Factors, Formula and Definition	7
●M7V Series Swash Plate Type Axial Piston Motor	
Specifications and Features	8
1. Ordering Code	9
2. Technical Information	
2-1. Specifications	12
2-2. Precautions for System Design	13
3. Regulators	
3-1. Two Position Displacement Control	14
– Electric Control	15
3-2. Proportional Displacement Control	16
– Electric Proportional Control	17
– Hydraulic Proportional Control	20
3-3. Pressure Related Control	24
– Without Pressure Increase	25
– With Pressure Increase	27
– With Pressure Increase and Hydraulic Remote Control	29
4. Dimensions	
4-1. M7V85	
◆ M7V85 Installation Dimensions	31
◆ M7V85 Port Size	33
◆ M7V85 Shaft End	
4-2. M7V112	
◆ M7V112 Installation Dimensions	34
◆ M7V112 Port Size	36
◆ M7V112 Shaft End	
4-3. M7V160	
◆ M7V160 Installation Dimensions	37
◆ M7V160 Port Size	39
◆ M7V160 Shaft End	
4-4. Regulators	40
M7V Series Inquiry Form	41
●M7X Series Fixed Displacement Type Axial Piston Motor	
Specifications and Features	42
5. Ordering Code	43
6. Technical Information	
6-1. Specifications	44
6-2. Precautions for System Design	45
7. Dimensions	
◆ M7X112 Installation Dimensions	46
◆ M7X112 Drain and Gauge Port	47
◆ M7X112 Shaft End	
M7X Series Inquiry Form	48

I . Applications / Product Usage





The following must be taken into consideration before use.

1. The operating condition of the products shown in this catalog varies depending upon each application. Therefore, the product suitability must be judged by the designer of the hydraulic system and/or the person who finalizes the technical specifications of the machine after analysis and testing. The product specification shall be determined based on the latest catalog and technical documents. The system must be designed taking into account the possibility of machine failure to ensure that all safety, warning, and application requirements are met.
2. For the proper use of the products, descriptions given in the SAFETY PRECAUTIONS must be observed.
3. The technical information in this catalog represents typical characteristics and performance of the products as of the published date.
4. If the products are intended to use in the following, please consult with Kawasaki in advance.
 - (1) Use the product under the operating conditions or environments other than those described in the technical documents.
 - (2) Use the product in the nuclear sector, aviation sector, medical sector, and/or food sector.
 - (3) Use the product in applications which may cause substantial harm to others and their property, and especially in applications where ensuring safety is a requirement.
5. The information described in this catalog is subject to change without notice. For the latest information, please contact Kawasaki.





II. Safety Precautions

Before using the product, you **MUST** read this catalog and **MUST** fully understand how to use the product. To use the product safely, you **MUST** carefully read all Warnings and Cautions in this catalog.













1. Cautions related to operation

-  - Use the personal protective equipment to prevent injury when the product is in operation.
-  - Some components are heavy. Handle the product carefully not to hurt your hands and lower back.
-  - Do not step on, hit or drop, or apply strong force to the product, as these actions may cause operation failure, product damage, or oil leakage.
-  - Wipe off any oil on the product or the floor completely, as oil can create slippery conditions that may cause drop of the product and personal injury.

2. Warnings and cautions related to installation and removal of the product

-  - Installation, removal, piping, and wiring must be done by a qualified technician.
-  - Make sure that the hydraulic power unit is turned off and that the electric motor or engine has completely stopped before starting installation or removal. You must also check that the system pressure has dropped to zero.
-  - Make sure that the power source is turned off before installing electric components to reduce the risk of electric shock.
-  - Clean the threads and the mounting surface to prevent damage or oil leakage. Inadequate cleaning may cause insufficient torque and broken seals.
-  - Use the designated bolts and fasten them with prescribed torque when installing the product. Use of undesignated bolts, and excessive or insufficient tightening torque may induce operation failure, damage, or oil leakage.

3. Warnings and cautions for operation

-  - Always equip the product with explosion or ignition protection if it is used in potentially explosive or combustible atmospheres.
 -  - Shield rotary parts, such as the motor and pump shaft, to avoid injury.
 -  - Stop operation immediately, and take proper measures when the abnormality such as unusual noise, oil leakage, and smoke is found. Continuing operation under such condition may bring about damage, a fire hazard, or injury.
 -  - Make sure that all pipes, hoses, and connecting points with pipes or hoses, are correctly connected and tightened before starting operation.
 -  - Use the product under the operating conditions and limitations described in the catalog, drawings, and specification sheets.
 -  - Do not touch the product in operation, to reduce the risk of skin burn.
 -  - Use the proper hydraulic oil and maintain the filtration at the recommended level to prevent premature wear and damage.
- ## 4. Cautions related to maintenance
-  - Never modify the product without approval from Kawasaki.
 -  - Disassembly of the product will void the warranty.
 -  - Keep the product clean and dry when storing or transporting.
 -  - The seals may need to be replaced if the product has been stored for an extended period of time.
 -  - Making adjustments of this product will result in the warranty being null and void.

III. Handling Precautions

1. Operating Fluid and Temperature Range

1) Operating fluid

Values shown in this catalog are based upon using mineral oil based anti-wear hydraulic fluid. To ensure optimal performance use of mineral oil based anti-wear hydraulic fluid is recommended.

2) Viscosity and temperature range

To minimize both oil and seal deterioration, a maximum operating temperature of 60°C should be considered. Please note that the regulator may become slow to respond when operating at low temperatures (below 20°C) in extreme cold environments. At such low temperature it is strongly suggested that a warm up cycle is introduced until an operating temperature of 20°C is achieved.

	Normal operating range	Allowable range
Viscosity [mm ² /s(cSt)]	10 to 200	10 to 1000
Fluid temperature [°C (°F)]	-20 to +90 (-4 to +194)	

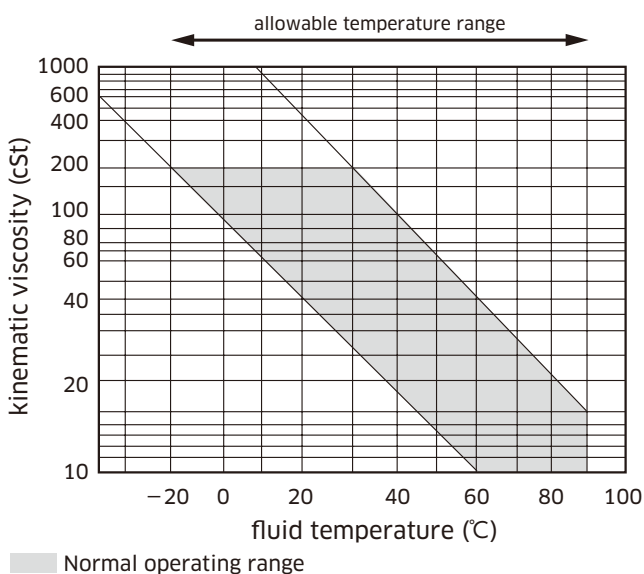

2. Filtration and Contamination Control

1) Filtration of working oil

The most important means to prevent premature damage to the motor and associated equipment and to extend its working life, is to ensure that hydraulic fluid contamination control of the system is working effectively.

This begins by ensuring that at the time of installation that all piping, tanks etc. are rigorously cleaned in a sanitary way. Flushing should be provided using an off line filtration system and after flushing the filter elements should be replaced.

2) Suggested acceptable contamination level

The relationship between contamination level and motor life is very difficult to predict as it depends on the type and nature of the contaminant present in the system. Sand or Silica in particular, due to its abrasive nature, does significantly reduce the expected life of a motor. Based on the precondition that there is no significant presence of Silica type substances then a minimum Cleanliness level of -/18/15 ISO 4406 or SAE AS 4059E Table 1 Class 9 (NAS 1638 Class 9).

III. Handling Precautions

3. Connection of Driving Shaft

- 1) Install the motor horizontally to the shaft direction.
- 2) Alignment should be within specifications below.
Parallel misalignment $\delta \leq 0.05\text{mm}$
(Dial gauge reading $a =$ below 0.10mm)
Angular misalignment $\alpha \leq 0.2\text{deg}$

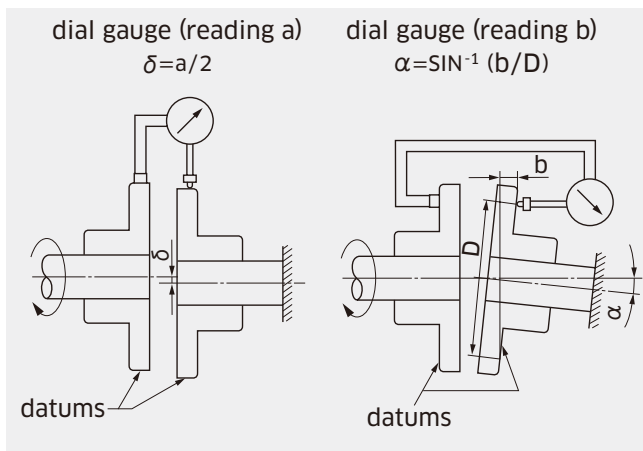

4. Oil Filling and Air Bleeding

1) Motor case filling

Be sure to fill the motor casing with oil through the drain port before start up. The motor contains bearings and high-speed sliding parts including pistons with shoes and a spherical bush that need to be continuously lubricated. Part seizure or total premature failure will occur very quickly if this procedure is not rigorously followed.

2) Air bleeding

Run the motor unloaded for a period of time to ensure that all residual air within the system is released.

3) Long term out of usage

It is undesirable to leave the motor out of use for a long period e.g. a year or more. In such a situation it is recommended that the motor is run for a short period on a more frequent basis even if it is just unloaded.

With regard to a motor held in storage then rotating the shaft on a frequent basis is sufficient. If the motor is left out for more than the suggested time it will require a service inspection.

5. Drain Piping

1) Location of the drain piping

Drain port at the highest position of the motor should be used.

Drain piping must be arranged as shown in the following figure so that the motor case is filled with the oil. The drain piping must be connected directly to the tank.

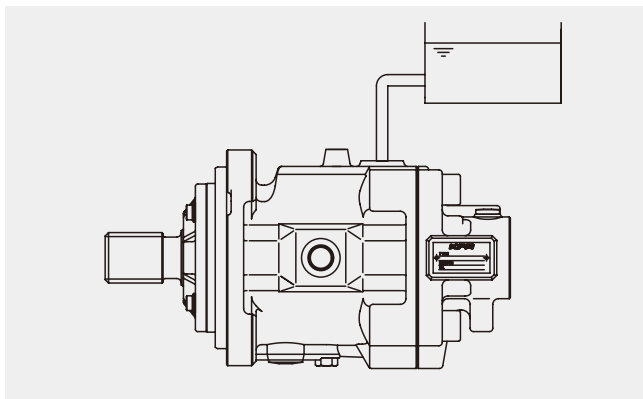

2) Size of the drain hose or pipe

The internal bore size must be larger in size than the drain port. Arrange the piping as short as possible.

3) Casing pressure

Permissible maximum case pressure is 0.2 MPa normally and 0.6 MPa peak. Refer to the following figure measured at the drain port of the motor.

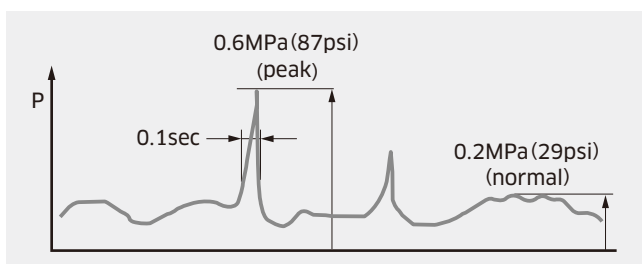

4) Influence of casing pressure on beginning of control

An increase in casing pressure affects the beginning of control of the variable motor when a proportional displacement control, or a pressure related control is adopted. An increase in casing pressure induces an increase in control pressure at the beginning of control, and has an influence on the control characteristics.

Please refer to the control options of M7V motors shown on page 11.

6. Thrust and Radial Load to the Shaft

1) Thrust load

Do not apply any form of thrust load to the shaft end.

2) Radial load

Radial load is acceptable under certain conditions. Please contact Kawasaki if a radial load to be applied to the shaft. Bearing life may be influenced and reduced depending on the load magnitude, the load position, and the load orientation.

7. Direction of rotation

Direction of rotation, viewed on drive shaft		
Direction	Clockwise	Counter Clockwise
Flow	Port A to B	Port B to A

IV. Conversion Factors, Formula and Definition

◆ Conversion Factors

	Formula	Note
Displacement	1 cm ³ = 0.061 in ³	
Pressure	1 MPa = 145 psi	
Flow	1 L/min = 0.264 gpm	US gallon
Torque	1 Nm = 0.74 lb ft	
Power	1 kW = 1.341 hp	
Weight	1 kg = 2.205 lb	

◆ Formula

	Metric system		Imperial system	
Input flow	$Q = q \times N / (1000 \times \eta_v)$	L/min	$Q = q \times N / (231 \times \eta_v)$	gal/min
Output torque	$T = q \times \Delta P \times \eta_m / 2\pi$	Nm	$T = q \times \Delta P \times \eta_m / 24\pi$	lbf ft
Output power	$L = T \times N / 9550 = Q \times \Delta P \times \eta_t / 60$	kW	$L = T \times N / 5252 = Q \times \Delta P \times \eta_t / 1714$	hp
Speed	$N = Q \times 1000 \times \eta_v / q$	min ⁻¹	$N = Q \times 231 \times \eta_v / q$	rpm

◆ Definition

q	= Motor displacement / rev.	cm ³ (in ³)
L	= Output power	hp
N	= Speed	min ⁻¹ (rpm)
N _{nom}	= Max. speed at maximum displacement	
ΔP	= P _{high} - P _{low}	MPa (psi)
P _{high}	= High pressure	MPa (psi)
P _{low}	= Low pressure	MPa (psi)
P _{nom}	= Nominal pressure	
T	= Output torque	Nm (lbf ft)
η _v	= Motor volumetric efficiency	
η _m	= Motor mechanical efficiency	
η _t	= Motor total efficiency	

M7V Series

Swash Plate Type Axial Piston Motor

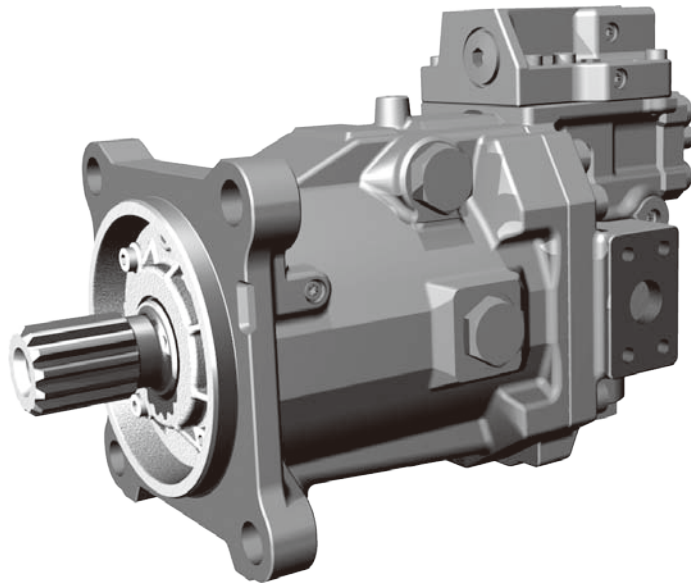

■ Specifications

Size : 85, 112, 160

Nominal Pressure : 40 MPa (5,800 psi)

Maximum Pressure : 45 MPa (6,500 psi)

■ General Descriptions

- Applicable to an open circuit and closed circuit.
- Applicable to construction machinery and industrial vehicles.
- Swash plate design allows for a compact motor.
- High power density
- Various control options make the motor suitable for a wide range of applications.

■ Features

High speed operation and smooth starting characteristics

Optimized rotary balance design enables high-speed performance and excellent starting characteristics.

Low speed operation

Superior performance in low speed operation provides excellent controllability.

Compact size

Swash plate configuration provides the more compact structure and flexibility in system design.

Long bearing life

Swash plate configuration results in longer bearing life.

1

M7V Ordering Code

Please fill in the Inquiry Form on page 41 in order to specify the requirement.

Model Code **M7V 112 A A 1 1 - A A 1 T1 X X X N - 01**

1. M7V Series

M7V Series, Variable Displacement, Axial Piston Motor, Applicable in Both Open and Closed Loops

2. Size

	85	112	160
Standard Size	●	●	●

3. Series Specifications

A	Standard
---	----------

4. Mounting Flange and Port Position

	Mounting	Port Position	85	112	160
A	SAE J744, 4-bolt Mount	Rear	●	●	●
B	SAE J744, 4-bolt Mount	Side	●	●	●
C	ISO3019-2, 4-bolt Mount	Rear	●	●	●
D	ISO3019-2, 4-bolt Mount	Side	●	●	●

5. Port and Flange Fixing Thread

	Threaded Port Type	Flange Fixing Thread Type	85	112	160
1	ANSI ISO11926	ANSI ASMEB1.1	●	●	●
2	ANSI ISO11926	Metric ISO724	○	○	○
3	Metric ISO6149	Metric ISO724	○	○	○
4	Parallel Piping ISO228	Metric ISO724	●	●	●

6. Shaft End

	Standard	Specifications	85	112	160
1	ANSI B92.1	1 1/2 in 17T 12/24DP	●	—	—
2	ANSI B92.1	1 3/4 in 13T 8/16DP	—	●	●
3	ANSI B92.1	2 in 15T 8/16DP	—	—	○
5	DIN 5480	W35x2x16x9 g	●	—	—
6	DIN 5480	W40x2x18x9 g	●	●	—
7	DIN 5480	W45x2x21x9 g	—	●	●
8	DIN 5480	W50x2x24x9 g	—	—	●
9	ANSI B92.1	1 1/4 in 14T 12/24DP	●	—	—

7. Maximum Displacement

Size	85	A : 85	●	B : 80	●	C : 75	●	D : 70	●
	112	A : 112	●	B : 107	●	C : 100	●	D : 95	●
	160	A : 160	●	B : 155	●	C : 150	●	D : 140	●

8. Minimum Displacement

Size	85	A : 51	●	B : 40	●	C : 30	●	D : —	—	E : —	—
	112	A : 68	●	B : 50	●	C : 40	●	D : 30	●	E : 22	●
	160	A : 96	●	B : 80	●	C : 60	●	D : 40	●	E : 32	●

9. Speed Sensor

		85	112	160
1	Without Speed Sensor	●	●	●
2	With Speed Sensor	○	○	○

● : Available
○ : Under development
— : Not available

1. M7V Ordering Code

Please fill in the Inquiry Form on page 41 in order to specify the requirement.

Model Code **M7V 112 A A 1 1 - A A 1 T1 X X X N - 01**

10. Regulator (See the table on page 11 for the possible combinations of regulator and optional valve options.)

			85	112	160	
T	T1	Two Position Displacement Control	Electric Control, 24V	●	●	●
	T2		Electric Control, 12V	●	●	●
E	E1	Electric Proportional Control	Negative Control, 24V	●	●	●
	E2		Positive Control, 24V	●	●	●
	E3		Negative Control, 12V	●	●	●
	E4		Positive Control, 12V	●	●	●
P	P1	Hydraulic Proportional Control	Negative Control, Pi = 2.5MPa	●	●	●
	P2		Positive Control, Pi = 2.5MPa	●	●	●
	P3		Negative Control, Pi = 1.0MPa	●	●	●
	P4		Positive Control, Pi = 1.0MPa	●	●	●
H	H1	Pressure Related Control	Without Pressure Increase	●	●	●
	H2		With Pressure Increase	●	●	●
	H3		With Pressure Increase and Hydraulic Remote Control	●	●	●

11. Optional Valves (See the table on page 11 for the possible combinations of optional valve and regulator options.)

			85	112	160	
X		Without Any Optional Valve	●	●	●	
A	A1	Pressure Control Valve	With a Pressure Control Valve	●	●	●
B	B1	Two Position Displacement Control	With Electric Two-Position Control Valve, 24V	●	●	●
	B2		With Electric Two-Position Control Valve, 12V	●	●	●

12. Accessories

			85	112	160
X		Without Any Accessory	●	●	●

13. Counter Balance Valve

			85	112	160
X		Without Counter Balance Valve	●	●	●
1		With Counter Balance Valve Hoist at CW rotation (A port inlet)	○	○	○
2		With Counter Balance Valve Hoist at CCW rotation (B port inlet)	○	○	○

14. Response Speed of Control

			85	112	160
N		Standard	●	●	●

15. Design Code

			85	112	160
**		01~	●	●	●

● : Available
○ : Under development
— : Not available

1. M7V Ordering Code

Please fill in the Inquiry Form on page 41 in order to specify the requirement.

Model Code ¹**M**²**7V** ³**1**⁴**1** ⁵**A** ⁶**A** ⁷**1** ⁸**1** ⁹**-** ¹⁰**A** ¹¹**A** ¹²**1** ¹³**T**¹⁴**1** ¹⁵**X** **X** **X** **N** **-** **01**

★ M7V Control Options

Note: The control options are common for all motor sizes.

Options for Regulator (Code [10])			Options for Optional Valves (code [11])			
			Without Any Optional Valve	With a Pressure Control Valve	With Electric Two Position Control Valve (24V)	With Electric Two Position Control Valve (12V)
		Options for Regulator (Code [10])	X	A1	B1	B2
T	T1	Two Position Displacement Control	Electric Control, 24V	●	—	—
	T2		Electric Control, 12V	●	—	—
E	E1	Electric Proportional Control	Negative Control, 24V	●	●	—
	E2		Positive Control, 24V	●	●	—
	E3		Negative Control, 12V	●	●	—
	E4		Positive Control, 12V	●	●	—
P	P1	Hydraulic Proportional Control	Negative Control, Pi = 2.5MPa	●	●	—
	P2		Positive Control, Pi = 2.5MPa	●	●	—
	P3		Negative Control, Pi = 1.0MPa	●	●	—
	P4		Positive Control, Pi = 1.0MPa	●	●	—
H	H1	Pressure Related Control	Without Pressure Increase	●	—	●
	H2		With Pressure Increase	●	—	●
	H3		With Pressure Increase and Hydraulic Remote Control	●	—	●

(Note)

For combination of two position control and pressure cut-off control, please select the pressure related control (code H) with two position control as option valve (code B1 or B2).

● : Available
 ○ : Under development
 — : Not available

2 Technical Information

2-1 Specifications

M7V series

Size		85	112	160
Min. Displacement : q_{\min}	cm ³ (in ³)	0 to 68 (0 to 4.2)	0 to 90 (0 to 5.5)	0 to 128 (0 to 7.9)
Max. Displacement : q_{\max}	cm ³ (in ³)	68 to 88.5 (4.2 to 5.2)	90 to 112 (5.5 to 6.9)	128 to 160 (7.9 to 9.8)
Max. Speed : $N_{\text{nom}} / N_{\text{max}}^{*1}$	min ⁻¹ (rpm)	3,900 / 6,150	3,550 / 5,600	3,100 / 4,900
Nominal pressure : P_{nom}^{*2}	MPa (psi)	40 (5,800)	40 (5,800)	40 (5,800)
Max. Pressure : P_{max}	MPa (psi)	45 (6,500)	45 (6,500)	45 (6,500)
Theoretical output torque	Nm (lbf ft)	541 (399)	713 (526)	1,019 (752)
Power	kW (hp)	221 (296)	265 (355)	331 (444)
Max. Flow : Q	L/min (gallon/min)	332 (88)	398 (105)	496 (131)
Moment of inertia	kg·m ²	0.011	0.015	0.027
Volume in the case	L (gallon)	0.8 (0.21)	1.0 (0.26)	1.5 (0.40)
Mass	kg (lb)	39 (86)	46 (101)	63 (139)
Temperature	°C (°F)	-20 to +115 (-4 to +239) at drain port -20 to +90 (-4 to +194) at inlet port		
Coating		Red synthetic resin primer		

Values shown in the table above are theoretical values

* 1 : N_{nom} : Max. speed at q_{\max} .

N_{max} : Max. speed at $q < 0.6q_{\max}$.

* 2 : Nominal pressure corresponds to the design pressure to provide proper performance, function, and service life.

2. Technical Information

2-2 Precautions for System Design

M7V series

◆ Minimum Boost Pressure

To prevent cavitation when the motor is operating in a pumping mode, a positive pressure is required at the suction port.

The figure on the right shows the minimum boost pressure requirement based on the regular operation. In case of a rapid change of the flow volume, more boost pressure must be applied.

◆ Minimum Back Pressure

To ensure the optimal performance and life time the back pressure is required at the lower pressure port.

Motor casing pressure must be ≤ 0.2 MPa.

◆ Permissible Displacement, Speed Related

The figure on the right shows permissible displacement in relation to the motor operating speed. Design the system not to exceed this requirement.

◆ Beginning of Control for Winch Device

For the safety reasons, winch device are not permissible with beginning control at q_{min} .

Minimum boost pressure

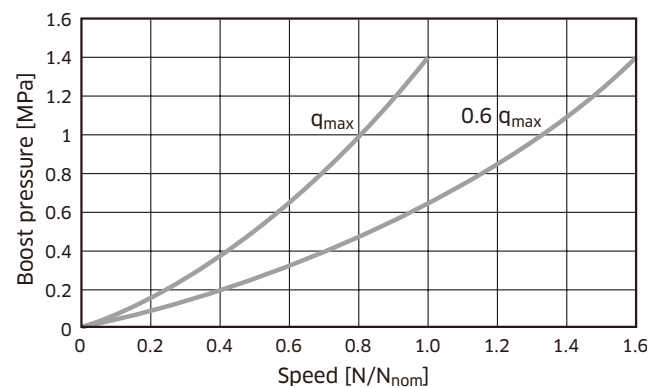

Minimum back pressure

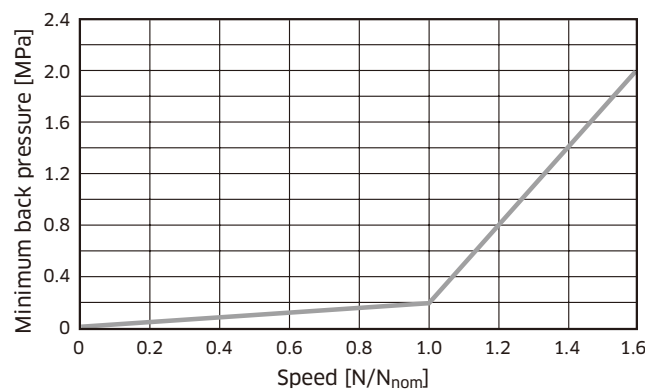

Permissible displacement

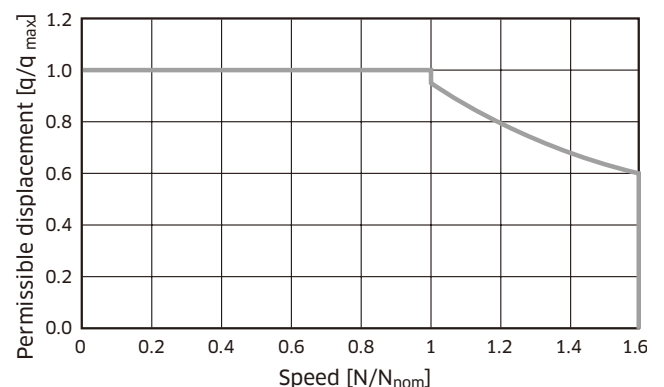

3 Regulators

3-1 Two Position Displacement Control

◆ Function

This control regulates motor displacement between minimum and maximum by energizing the solenoid. When the solenoid is energised the motor switches to minimum displacement. Once the solenoid is de-energised the motor switches to maximum displacement.

◆ Control Options for Two Position Displacement Control

● Pressure control

An M7V motor with two position displacement control can additionally have pressure control function. Refer to page 24 for details.

If the motor is equipped with both two position displacement control and pressure control, pressure control overrides proportional displacement control.

Under pressure control the motor maintains minimum displacement until the operating pressure reaches the pressure setpoint. Upon reaching the pressure setpoint the motor increases displacement to maximum to obtain the required output torque, while controlling the operating pressure. If the motor reaches maximum displacement without sufficient output torque, the motor increases pressure until the required output torque is attained.

For safety reasons, winch devices are not permissible with beginning control at q_{\min} .

3. Regulators

3-1 Two Position Displacement Control - Electric Control

Ordering Code [10] [11] : T1X and T2X

◆ Function

Two position displacement control (electric control) regulates motor displacement between minimum and maximum by energizing the solenoid.

Control pressure is internally supplied by the port with the highest pressure.

For safety reasons, winch devices are not permissible with beginning control at q_{min} .

[Note]

Required minimum operating pressure for control : 2.0MPa

Control type	T1X, T2X	
Electric signal	OFF	ON
Displacement	Max.	Min.
Speed	Min.	Max.

◆ Control Characteristics

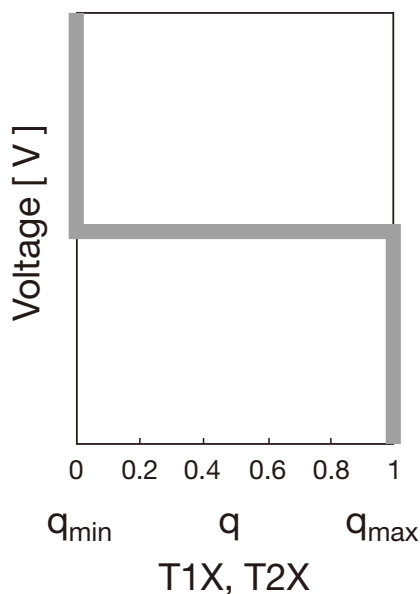

The control characteristics in the above is not adjustable.

The above data are independent of the motor size.

◆ Solenoid Specifications

Code	T1X	T2X
Voltage	DC24V	DC12V
Resistance (20°C)	41.5 Ω	9.4 Ω
Rated electric power consumption (20°C)	≤ 17 W	
Connector type	Deutsch DT04-2P	

◆ Hydraulic Circuit

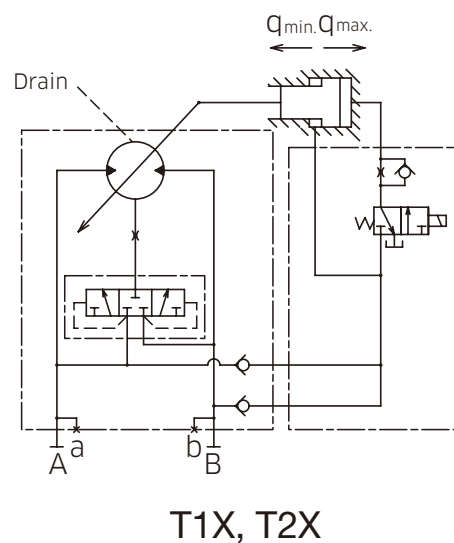

3. Regulators

3-2 Proportional Displacement Control

◆ Function

There are two kinds of control methods in the proportional displacement control, namely electric proportional control and hydraulic proportional control. Proportional displacement control regulates motor displacement in proportion to either the input current of solenoid or external pilot pressure .

[Note]

As stated in page 6, casing pressure has influence on proportional displacement control both electric and hydraulic. An increase in casing pressure induces an increase in control pressure at the beginning of control, and hence parallel shift of control characteristics.

◆ Control Options for Proportional Displacement Control

● Pressure control

An M7V motor equipped with proportional control (either electric or hydraulic) can have pressure control function by using an optional valve (see page 11).

If the motor has both proportional control (either electric or hydraulic) and pressure control, pressure control overrides proportional displacement control.

Under pressure control the motor maintains minimum displacement until the operating pressure reaches the pressure setpoint. Upon reaching the pressure setpoint the motor increases displacement to maximum to obtain the required output torque, while controlling the operating pressure. If the motor reaches maximum displacement without sufficient output torque, the motor increases pressure until the required output torque is attained.

For safety reasons, winch devices are not permissible with beginning control at q_{\min} .

3. Regulators

3-2 Proportional Displacement Control - Electric Proportional Control

Ordering Code [10] [11] : E1X, E2X, E3X and E4X.

◆ Function

Displacement is steplessly controlled between two preset values, from maximum to minimum and vice versa, in proportion to the input current of solenoid.

Electric proportional control delivers negative or positive displacement controls which are proportional to the input current: negative control type E1X and E3X reduce displacement from maximum to minimum against an increase in the input current, while positive control type E2X and E4X increase displacement from minimum to maximum with an increase in the input current.

Control pressure is internally supplied by the port with the highest pressure.

[Note]

Required minimum operating pressure for control: 2.0 MPa.

The above data are independent of the motor size.

◆ Solenoid Specifications

Control type	E1*, E2*	E3*, E4*
Voltage	DC24V	DC12V
Rated current (20°C)	0.7 A	1.6 A
Resistance (20°C)	15.0 Ω	3.3 Ω
Rated power consumption (20°C)	≤ 17 W	
Connector type	Deutsch DT04-2P	
Recommended dither condition	100 Hz, 200 mAp-p	150 Hz, 600 mAp-p

“*” = “X” (without any optional valve)

“A” (with a pressure control valve)

3. Regulators

3-2 Proportional Displacement Control - Electric Proportional Control

Ordering Code [10] [11] : E1X, E2X, E3X and E4X.

◆ Control Characteristics

Negative Control

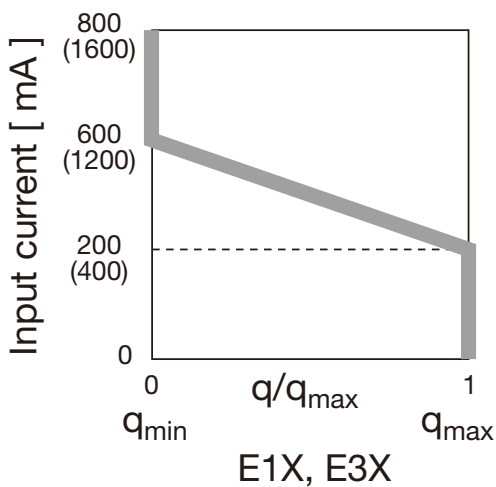

Positive Control

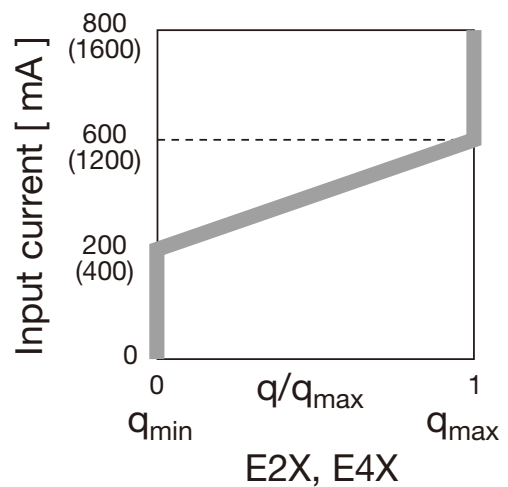

Control type		E1X, E3X (Negative control)		E2X, E4X (Positive control)	
Input current	DC 24V (DC 12V)	200mA (400mA)	600mA (1200mA)	200mA (400mA)	600mA (1200mA)
Displacement		Max.	Min.	Min.	Max.
Speed		Min.	Max.	Max.	Min.

Input current in () is for the voltage of 12 V DC.

The control characteristics of E1X, E2X, E3X and E4X are not adjustable.

◆ Hydraulic Circuit

Negative Control

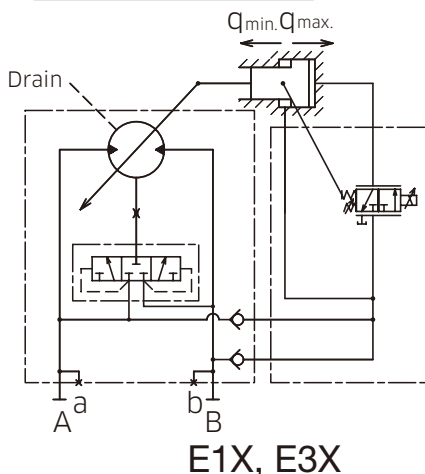

Positive Control

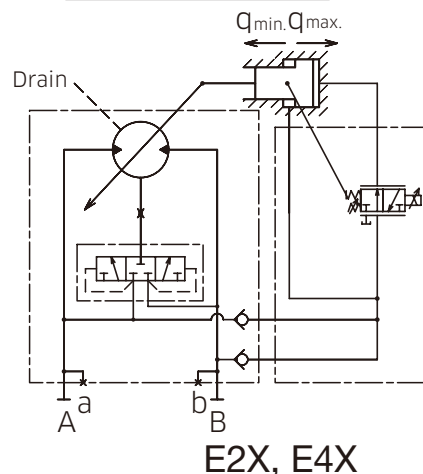

The above data are independent of the motor size.

3. Regulators

3-2 Proportional Displacement Control - Electric Proportional Control with Pressure Control Valve

Ordering Code [10] [11] : E1A1, E2A1, E3A1 and E4A1.

◆ Hydraulic Circuit

Negative Control with Pressure Control Valve

Positive Control with Pressure Control Valve

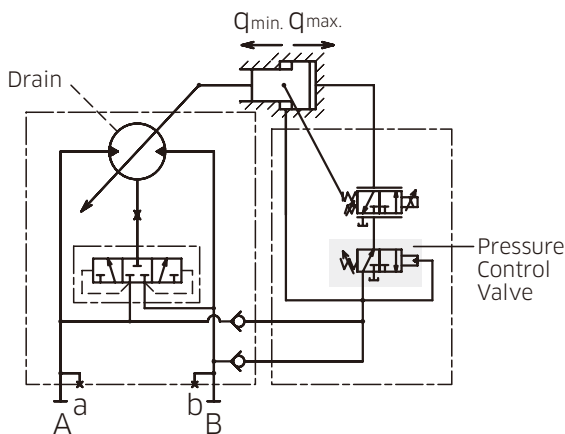

E1A1, E3A1

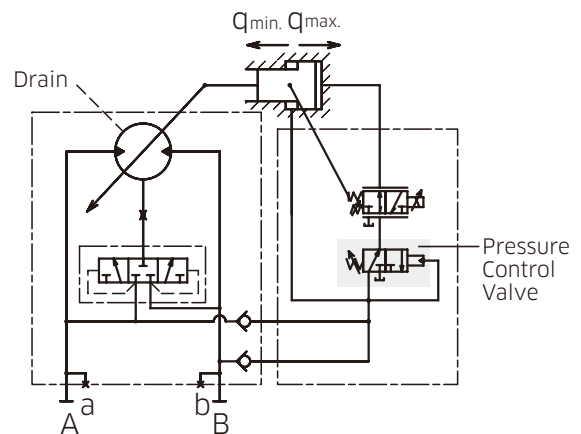

E2A1, E4A1

Electric proportional control can be combined with pressure control by using an optional valve. If the motor is equipped with electric proportional control and pressure control, pressure control overrides electric proportional control.

Under pressure control the motor maintains minimum displacement until the operating pressure reaches the pressure setpoint. Upon reaching the pressure setpoint the motor increases displacement to maximum to obtain the required output torque, while controlling the operating pressure. If the motor reaches maximum displacement without sufficient output torque, the motor increases pressure until the required output torque is attained.

Adjustable setting range of the pressure valve: 8~35 MPa

For safety reasons, winch devices are not permissible with beginning control at q_{min} .

3. Regulators

3-2 Proportional Displacement Control - Hydraulic Proportional Control

Ordering Code [10] [11] : P1X, P2X, P3X and P4X.

◆ Function

Hydraulic proportional control regulates motor displacement between maximum to minimum in response to pilot pressure externally supplied to a regulator.

This control delivers negative or positive displacement controls which are proportional to an increase in external pilot pressure: negative control type P1X and P3X reduce displacement from maximum to minimum against an increase in pilot pressure, while positive control type P2X and P4X increase displacement from minimum to maximum with an increase in pilot pressure.

Control pressure is internally supplied by the port with the highest pressure.

[Note]

Required minimum operating pressure for control: 2.0 MPa

Max. permissible pilot pressure : 10.0 MPa

Control type	P1X		P2X		P3X		P4X	
Pilot pressure	1.0 MPa*	3.5 MPa	1.0 MPa*	3.5 MPa	0.5 MPa*	1.5 MPa	0.5 MPa*	1.5 MPa
Displacement	Max.	Min.	Min.	Max.	Max.	Min.	Min.	Max.
Speed	Min.	Max.	Max.	Min.	Min.	Max.	Max.	Min.

The pressure with * in the above table is the standard start pressure at the beginning of each control. Adjustable range of pilot pressure at the beginning of control is shown in each control characteristics.

The above data are independent of the motor size.

3. Regulators

3-2 Proportional Displacement Control - Hydraulic Proportional Control

Ordering Code [10] [11] : P1X, P2X, P3X and P4X.

◆ Control Characteristics

Negative Control

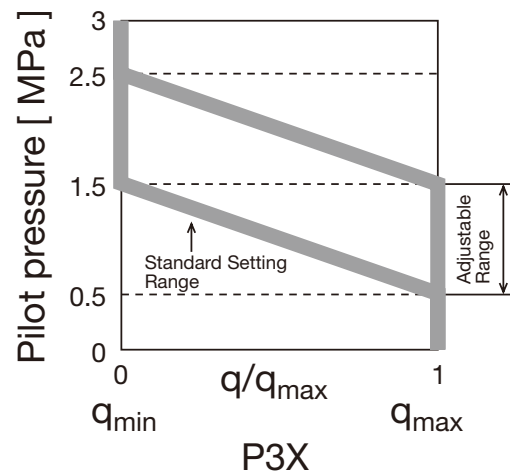
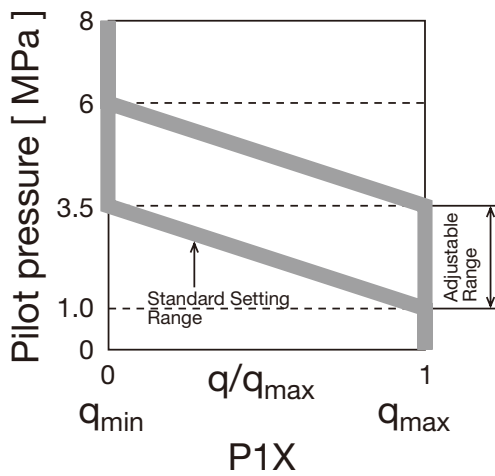

P1X is different from P3X in adjustable range and the control start pressure. Adjustable range of P1X is 2.5 MPa, while that of P3X is 1.0 MPa. Also, the control start pressure of P1X is 1.0 MPa, while that of P3X is 0.5 MPa.

Positive Control

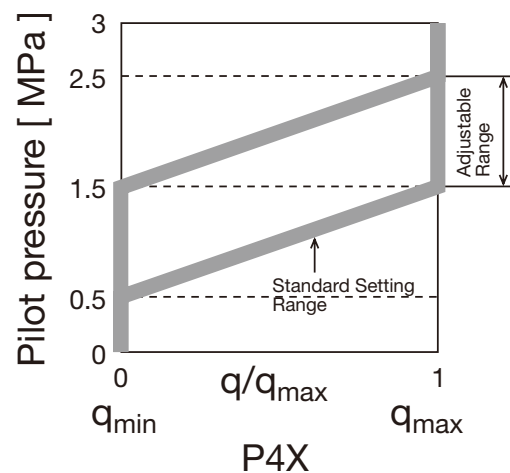
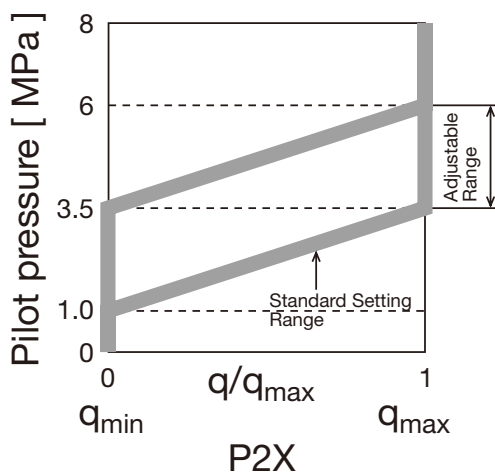

P2X is different from P4X in adjustable range and the control start pressure. Adjustable range of P2X is 2.5 MPa, while that of P4X is 1.0 MPa.

Also, the control start pressure of P2X is 1.0 MPa, while that of P4X is 0.5 MPa.

[Note]

The above are the standard control characteristics of hydraulic proportional control. If non-standard characteristics is required, please contact Kawasaki.

3. Regulators

3-2 Proportional Displacement Control - Hydraulic Proportional Control

Ordering Code [10] [11] : P1X, P2X, P3X and P4X.

◆ Hydraulic Circuit

Negative Control

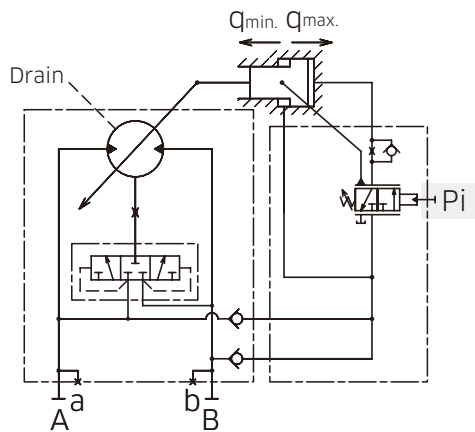

P1X, P3X

Positive Control

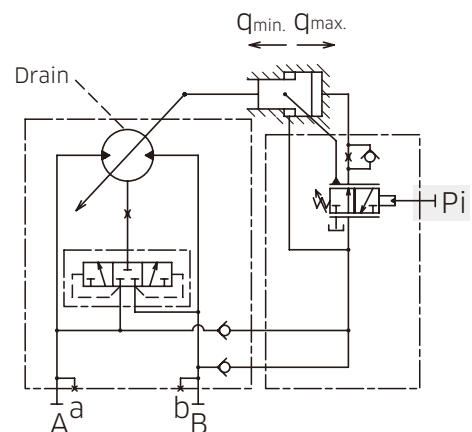

P2X, P4X

External pilot pressure is supplied via port Pi.

For safety reasons, winch devices are not permissible with beginning control at q_{min} .
The above data are independent of the motor size.

Allowable maximum pilot pressure (Pi): 10 MPa

3. Regulators

3-2 Proportional Displacement Control - Hydraulic Proportional Control with Pressure Control Valve

Ordering Code [10] [11] : P1A1, P2A1, P3A1 and P4A1.

◆ Hydraulic Circuit

Negative Control with Pressure Control Valve

Positive Control with Pressure Control Valve

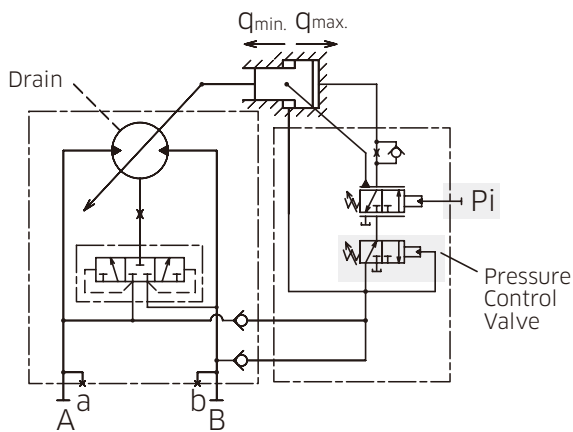

P1A1, P3A1

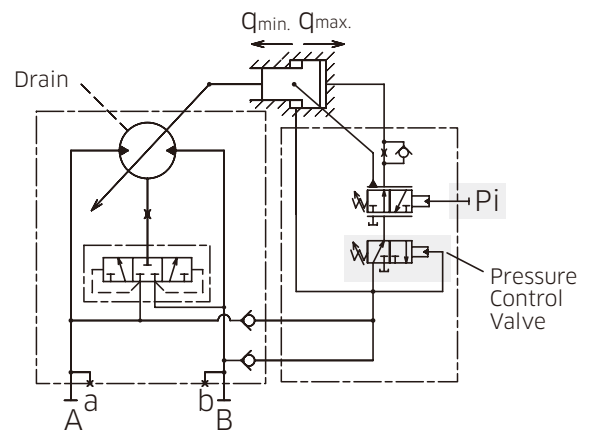

P2A1, P4A1

Hydraulic proportional control can be combined with pressure control by using an optional valve in an M7V motor. If it is equipped with both hydraulic proportional control and pressure control, the latter overrides the former.

Displacement shifts from minimum to maximum, when the operating pressure reaches the pressure setpoint. The motor increases displacement by gradually increasing the operating pressure until the required output torque is attained. If displacement reaches its maximum value without sufficient output torque, the operating pressure will rise until the required output torque is obtained.

Setting range of the pressure control valve: 8 to 35 MPa

For safety reasons, winch devices are not permissible with beginning control at q_{min} . The above data are independent of the motor size.

3. Regulators

3-3 Pressure Related Control

◆ Function

There are three kinds of control types in the pressure related control, that is constant pressure control (pressure control without pressure increase), pressure control with pressure increase, and pressure control with pressure increase and hydraulic remote control.

Displacement is controlled between minimum and maximum in line with the operating pressure.

Minimum displacement is maintained until the operating pressure reaches the pressure setpoint, and upon reaching the pressure setpoint of control it shifts to maximum displacement by controlling the operating pressure until the required output torque is obtained.

[Note]

As stated in page 6, casing pressure affects the pressure related control. An increase in casing pressure induces an increase in control pressure at the beginning of control, and thus the parallel shift of the control characteristics.

◆ Control Options for Constant Pressure Control

● Two position displacement control

An M7V motor with constant pressure control can add two position control by adopting an optional two position control valve (see page 11).

When an M7V motor is equipped with both constant pressure control and two position displacement control, constant pressure control overrides two position displacement control.

For detail of two position displacement control see page 15.

For safety reasons, winch devices are not permissible with beginning control at q_{\min} .

3. Regulators

3-3 Pressure Related Control - Without Pressure Increase

Ordering Code [10] [11] : H1X

◆ Function

Displacement is controlled between minimum and maximum in line with the operating pressure. Minimum displacement is maintained until the operating pressure reaches a setpoint, and upon reaching the pressure setpoint it shifts to maximum displacement until the required output torque is obtained, while maintaining the set pressure.

Control pressure is internally supplied by the port with the highest pressure.

For safety reasons, winch devices are not permissible with beginning control at q_{min} .

Control type	H1X	
Displacement	Min.	Max.
Speed	Max.	Min.
Adjustable range for the control start pressure	8 to 35 MPa	

◆ Control Characteristics

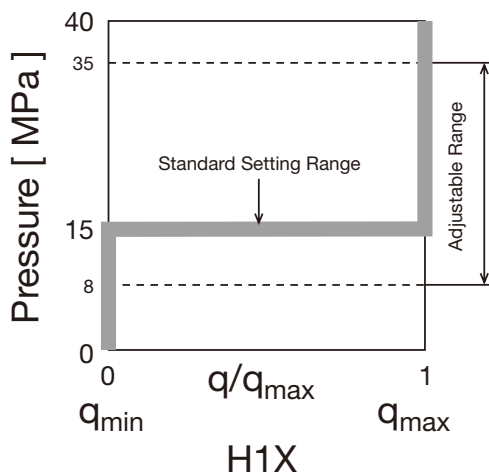

Control pressure in H1X is factory set at 15 MPa, and the above shows the standard control characteristics.

If non-standard characteristics is required, please contact Kawasaki.

The above data are independent of the motor size.

◆ Hydraulic Circuit

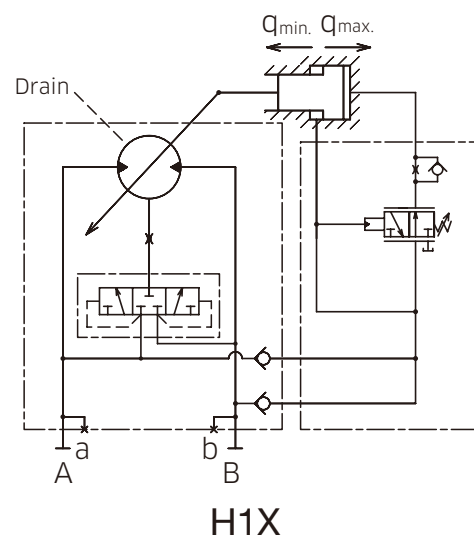

3. Regulators

3-3 Pressure Related Control – Without Pressure Increase with Two Position Control Valve

Ordering Code [10] [11] : H1B1 and H1B2

◆ Hydraulic Circuit

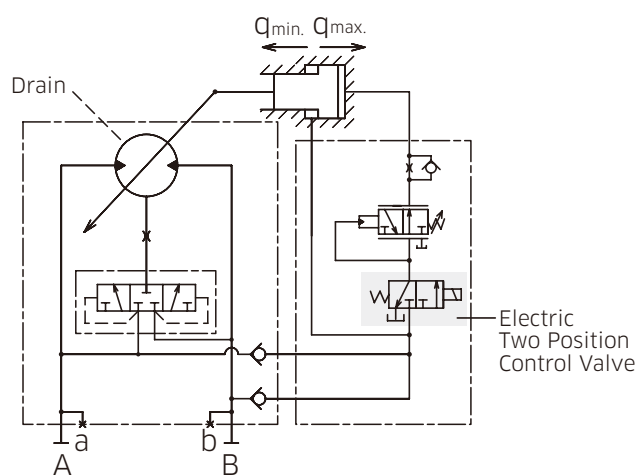

H1B1, H1B2

Pressure related control (pressure control without pressure increase) can be combined with electric two position displacement control by using an electric two position control valve. If the motor has both pressure related control and electric two position displacement control, pressure related control overrides electric two position displacement control.

Specifications of electric two position control valve is shown below.

For safety reasons, winch devices are not permissible with beginning control at q_{min} .

◆ Solenoid Specifications

Code	B1	B2
Voltage	DC24V	DC12V
Resistance (20°C)	41.5 Ω	9.5 Ω
Rated power consumption (20°C)	≤ 17 W	
Connector type	Deutsch DT04-2P	

The above data are independent of the motor size.

3. Regulators

3-3 Pressure Related Control - With Pressure Increase

Ordering Code [10] [11] : H2X

◆ Function

Displacement is controlled in line with operating pressure and load conditions.

The motor maintains minimum displacement until the operating pressure reaches a setpoint, and when it exceeds the pressure setpoint it shifts to maximum displacement.

Displacement increases until the required output torque is obtained. If displacement reaches maximum without sufficient output torque, the operating pressure will rise until the required motor output torque is attained.

Control pressure is internally supplied by the port with the highest pressure.

For safety reasons, winch devices are not permissible with beginning control at q_{min} .

Control type	H2X	
Displacement	Min.	Max.
Speed	Max.	Min.
Factory setting of the control start pressure	10 MPa	
Pressure increment	20 MPa	

◆ Control Characteristics

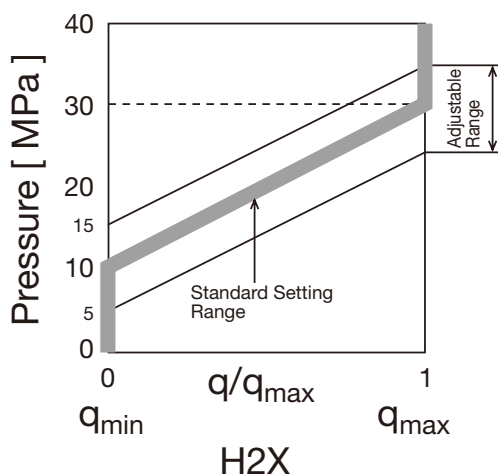

In H2 control the start of control pressure is factory set at 10 MPa, and the above shows the standard control characteristics.

If non-standard characteristics is required, please contact Kawasaki.

The above data are independent of the motor size.

◆ Hydraulic Circuit

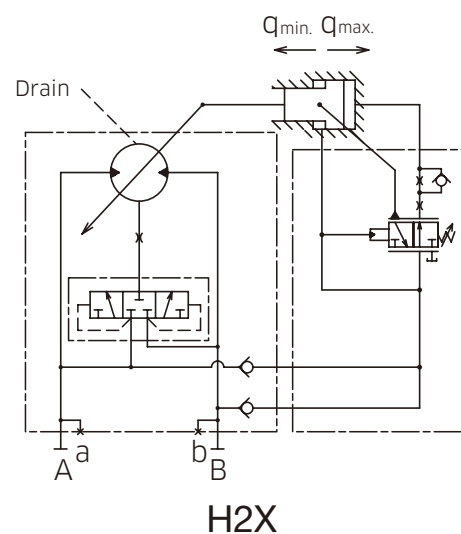

3. Regulators

3-3 Pressure Related Control – With Pressure Increase and Two Position Control Valve

Ordering Code [10] [11] : H2B1 and H2B2

◆ Hydraulic Circuit

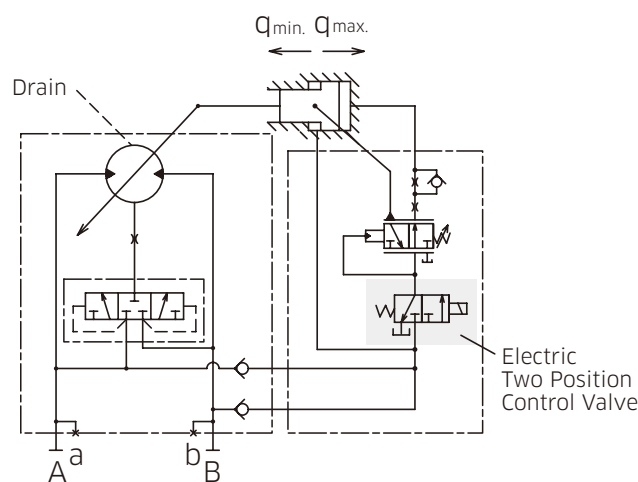

H2B1, H2B2

Pressure related control (Pressure control with pressure increase) can be combined with electric two position displacement control by using an optional two position control valve. If the motor has both pressure related control and electric two position displacement control, pressure related control overrides electric two position displacement control.

Specifications of electric two position control valve is shown below.

For safety reasons, winch devices are not permissible with beginning control at q_{min} .

◆ Solenoid Specifications

Code	B1	B2
Voltage	DC24V	DC12V
Resistance (20°C)	41.5 Ω	9.5 Ω
Rated power consumption (20°C)	≤ 17 W	
Connector type	Deutsch DT04-2P	

The above data are independent of the motor size.

3. Regulators

3-3 Pressure Related Control – With Pressure Increase and Hydraulic Remote Control

Ordering Code [10] [11] : H3X

◆ Function

H3X control allows variations at the start of control pressure and control characteristics by applying the external remote control pressure. The application of external remote control pressure in H3X control reduces the control pressure at the beginning of the constant pressure control, and induces a parallel shift in the control characteristics.

Control pressure is internally supplied by the port with the highest pressure.

For safety reasons, winch devices are not permissible with beginning control at q_{min} .

Control type	H3X
Standard setting of the control start pressure	10 MPa
External remote control sensitivity at port P1	1.7 MPa / 0.1 MPa
Max. permissible remote control pressure	≤ 10 MPa

◆ Control Characteristics

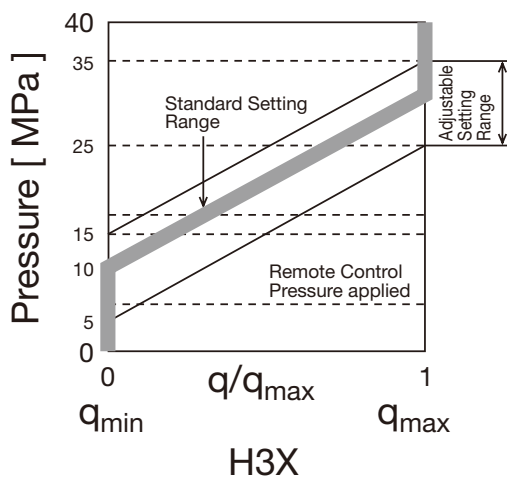

The remote pressure control in H3 type control provides variations in the control characteristics of H3 pressure related control.

For 0.1 MPa of remote control pressure the pressure at the start of control reduces by 1.7 MPa. With the remote pressure control the control characteristics shifts in parallel.

The above data are independent of the motor size.

◆ Hydraulic Circuit

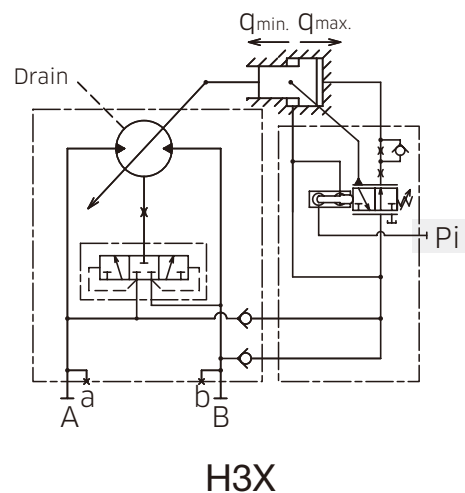

External remote control pressure is supplied via port Pi.

(Note)

In case Pi port is not used please connect the port Pi to drain line.

Allowable maximum pilot pressure (Pi): 10 MPa

3. Regulators

3-3 Pressure Related Control – With Pressure Increase and Hydraulic Remote Control, and Two Position Control Valve

Ordering Code [10] [11] : H3B1 and H3B2

◆ Hydraulic Circuit

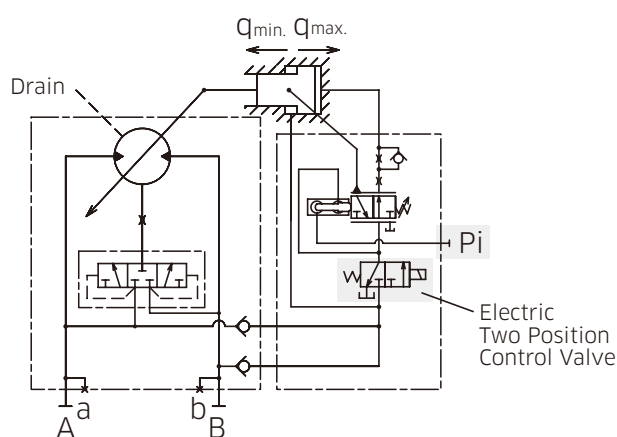

H3B1, H3B2

Pressure related control (Pressure control with pressure increase and hydraulic remote control) can be combined with electric two position displacement control by using an optional two position control valve. If the motor has both pressure related control and electric two position displacement control, pressure related control overrides electric two position displacement control.

Specifications of electric two position control valve is shown below.

For safety reasons, winch devices are not permissible with beginning control at q_{\min} .

◆ Solenoid Specifications

Code	B1	B2
Voltage	DC24V	DC12V
Resistance (20°C)	41.5 Ω	9.5 Ω
Rated power consumption (20°C)	≤ 17 W	
Connector type	Deutsch DT04-2P	

The above data are independent of the motor size.

4 Dimensions

4-1 M7V85 Installation Dimensions

* Dimensions in mm.

◆ M7V85 SAE Mounting, Flange Ports at Side

Model Code : M7V 85 A B 1 1 - * * 1 H1 X X X N - * *

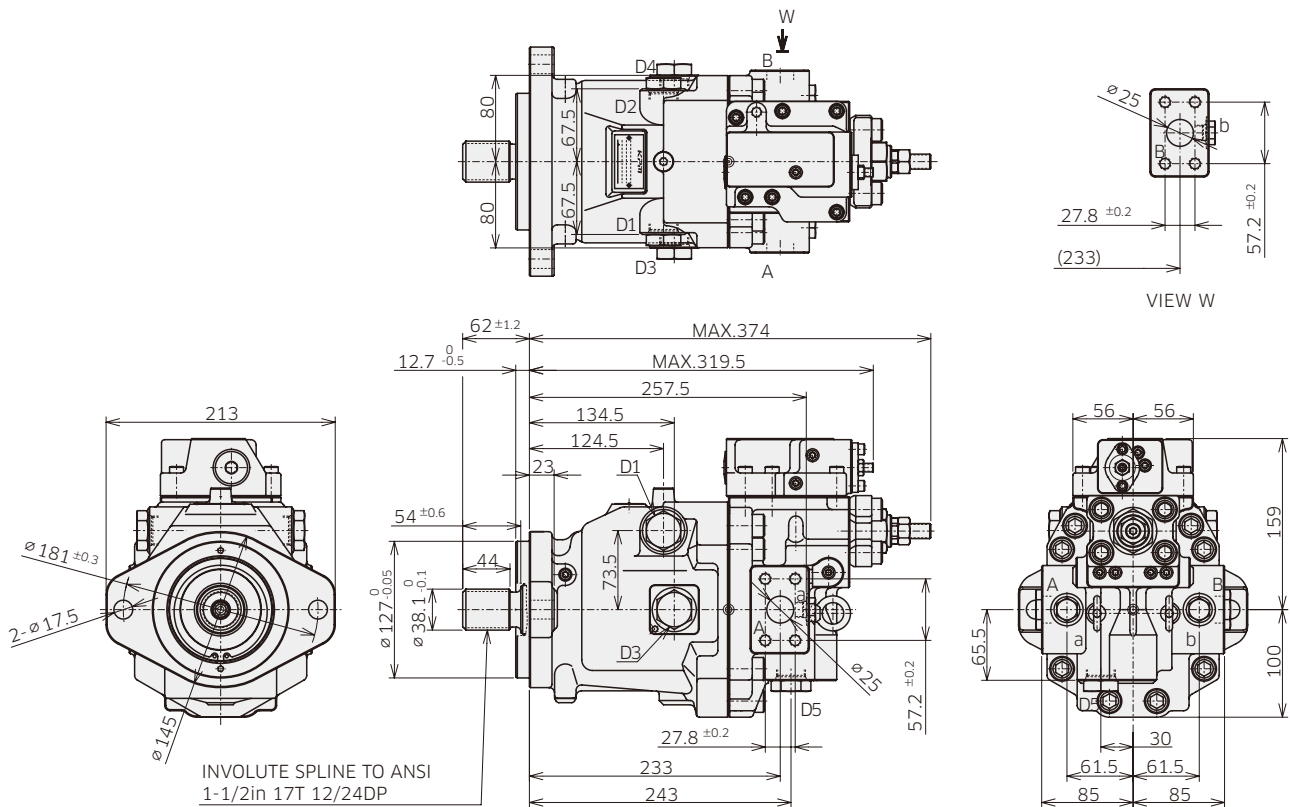

◆ M7V85 SAE Rear Port

Model Code : M7V 85 A A 1 1 - * * 1 H1 X X X N - * *

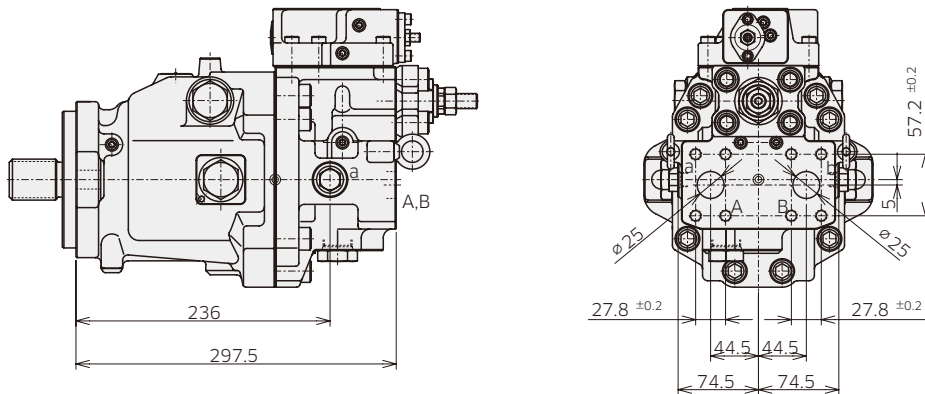

Refer to the page 40 for dimensions with other regulator options.

4. Dimensions

4-1 M7V85 Installation Dimensions

* Dimensions in mm.

◆ M7V85 ISO Mounting, Flange Ports at Side

Model Code : M7V 85 A D 4 5 - * * 1 H1 X X X N - * *

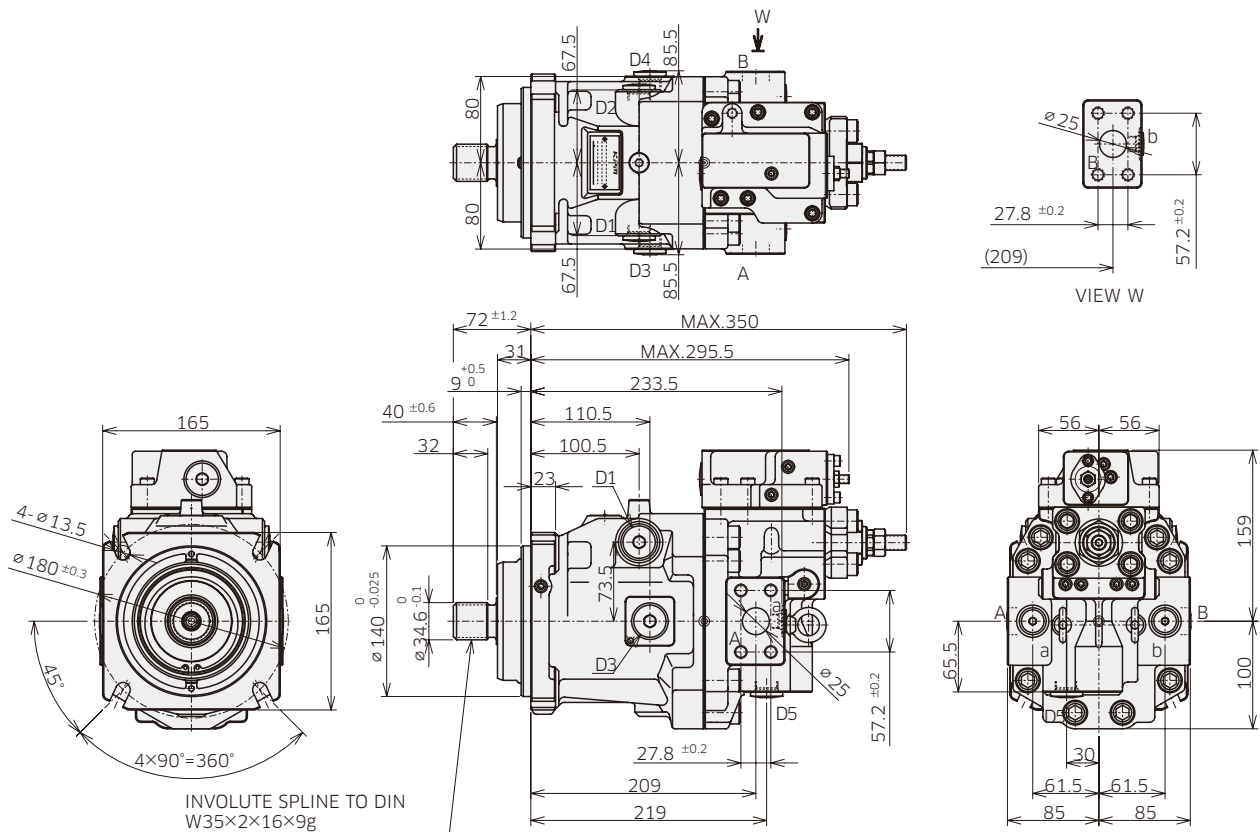

◆ M7V85 ISO Rear Port

Model Code : M7V 85 A C 4 5 - * * 1 H1 X X X N - * *

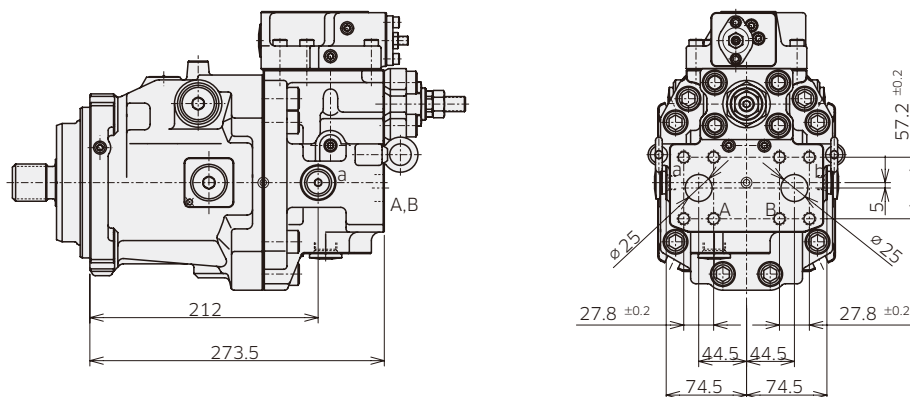

Refer to the page 40 for dimensions with other regulator options.

4. Dimensions

4-1 M7V85

◆ Port Size (Ordering Code [5]) Thread Port

ANSI thread type (Code : 1,2)

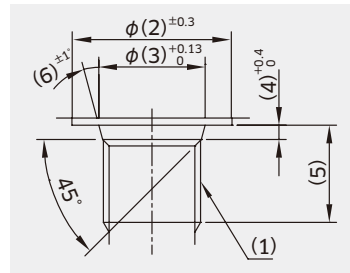

* Dimensions in mm.

	Symbol	(1)	(2)	(3)	(4)	(5)	(6)	Tightening torque (Nm)
Gauge port	a, b	9/16-18UNF-2B	25	15.6	2.5	12.7	12	59
Pilot port	Pi	9/16-18UNF-2B	25	15.6	2.5	12.7	12	59
Drain port	D1 to D5	1-1/16-12UN-2B	41	29.2	3.3	12.7	15	170

Metric thread type (Code : 3)

	Symbol	(1)	(2)	(3)	(4)	(5)	(6)	Tightening torque (Nm)
Gauge port	a, b	M14×1.5	25	15.8	2.4	12.5	15	47
Drain port	D1 to D5	M27×2	40	29.4	3.1	12.7	15	180

Parallel piping thread type (Code : 4)

	Symbol	(1)	(2)	(3)	(4)	(5)	(6)	Tightening torque (Nm)
Gauge port	a, b	G 1/4	25	15.6	2.5	15	15	36
Pilot port	Pi	G 1/4	25	15.6	2.5	14	15	36
Drain port	D1 to D5	G 1/2	34	22.6	2.5	12.7	15	108

Flange port

Port thread type code	d1	A	B	D	Tightening torque (Nm)
1	7/16-14UNC-2B	27.8	57.2	25	98
2, 3, 4	M12	27.8	57.2	25	98

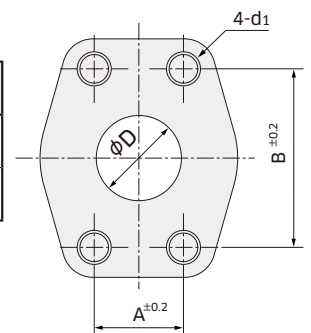

◆ Shaft End (Ordering Code [6])

ANSI B92.1a
(1-1/2in 17T 12/24DP)

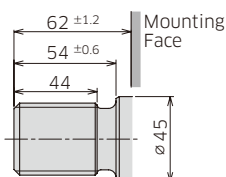

Code : 1

DIN 5480
(W35x2x16x9g)

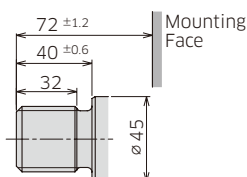

Code : 5

DIN 5480
(W40x2x18x9g)

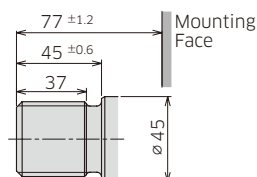

Code : 6

ANSI B92.1a
(1-1/4in 14T 12/24DP)

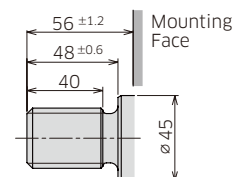

Code : 9

4. Dimensions

4-2 M7V112 Installation Dimensions

* Dimensions in mm.

◆ M7V112 SAE Mounting, Flange Ports at Side

Model Code : M7V 112 A B 1 2 - * * 1 H1 X X X N - * *

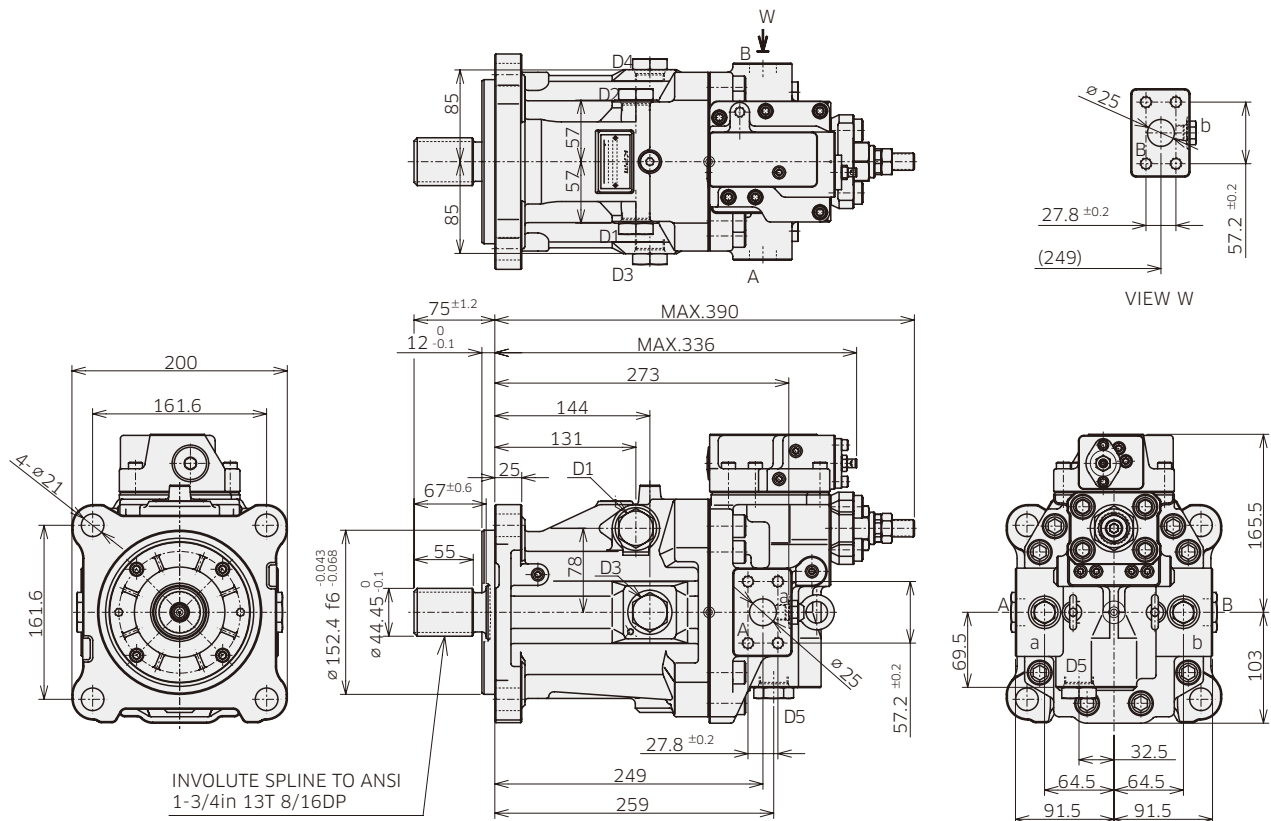

◆ M7V112 SAE Rear Port

Model Code : M7V 112 A A 1 2 - * * 1 H1 X X X N - * *

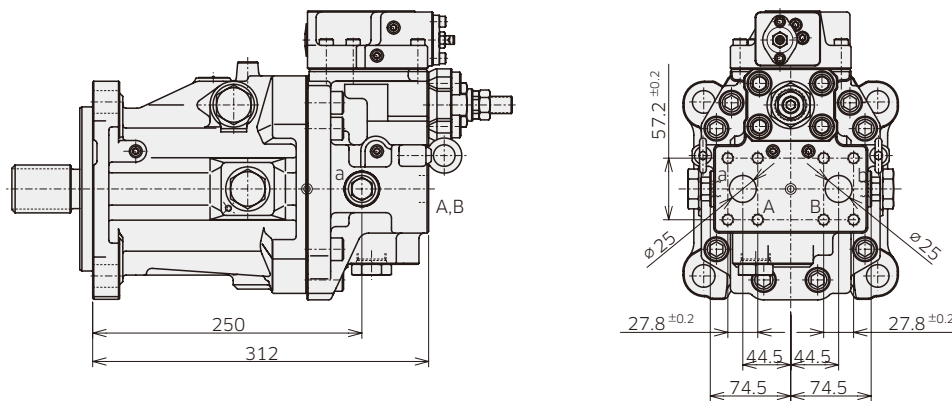

Refer to the page 40 for dimensions with other regulator options.

4. Dimensions

4-2 M7V112 Installation Dimensions

* Dimensions in mm.

◆ M7V112 ISO Mounting, Flange Ports at Side

Model Code : M7V 112 A D 4 7 - * * 1 H1 X X X N - * *

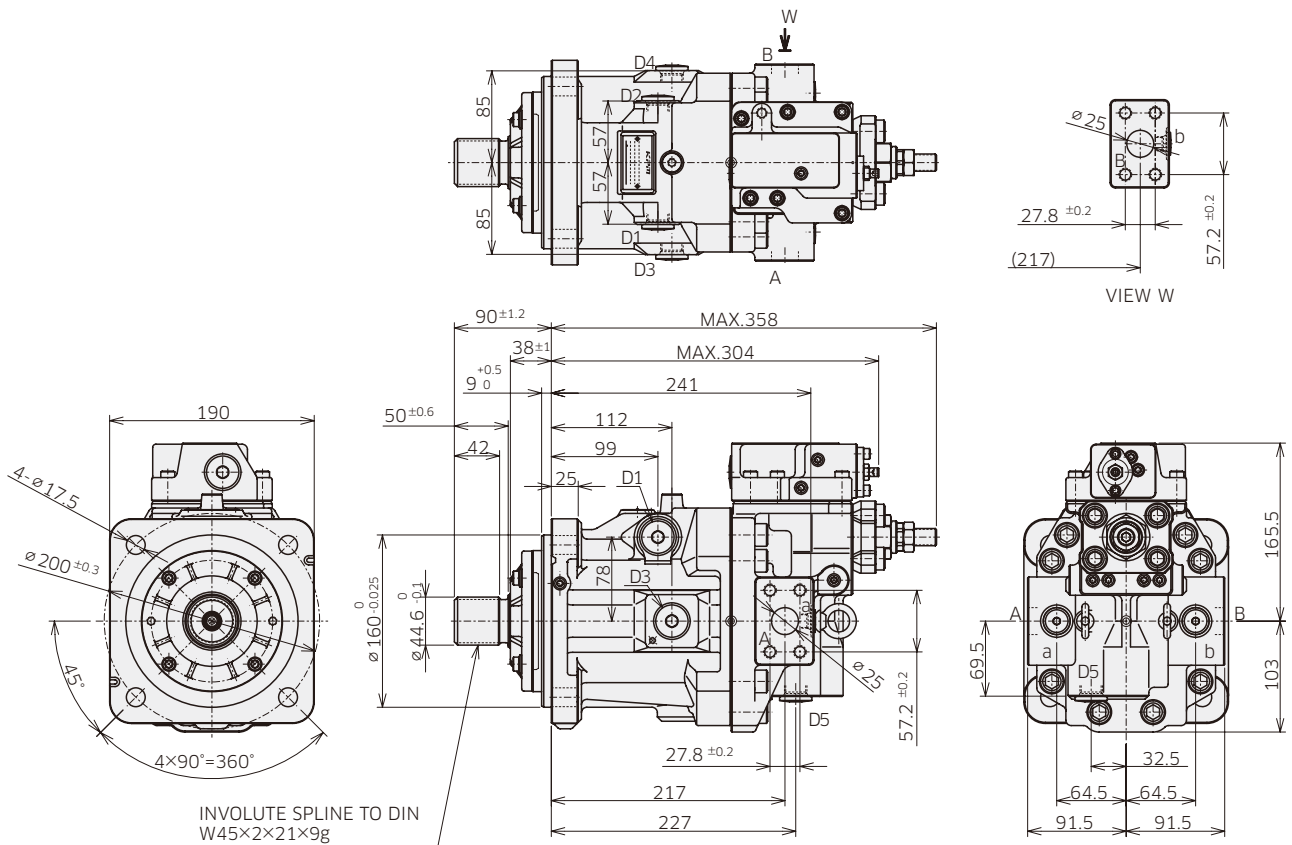

◆ M7V112 ISO Rear Port

Model Code : M7V 112 A C 4 7 - * * 1 H1 X X X N - * *

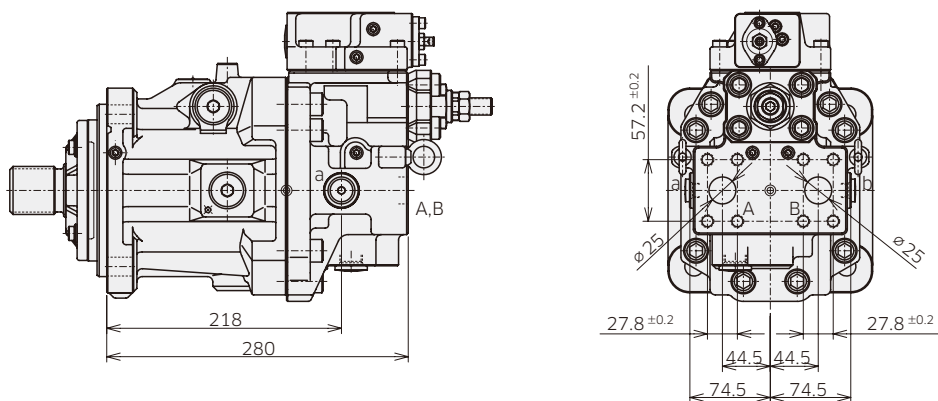

Refer to the page 40 for dimensions with other regulator options.

4. Dimensions

4-2 M7V112

◆ Port Size (Ordering Code [5]) Thread Port

ANSI thread type (Code : 1,2)

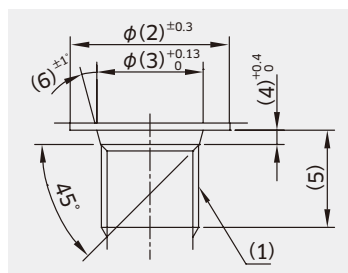

* Dimensions in mm.

	Symbol	(1)	(2)	(3)	(4)	(5)	(6)	Tightening torque (Nm)
Gauge port	a, b	9/16-18UNF-2B	25	15.6	2.5	12.7	12	59
Pilot port	Pi	9/16-18UNF-2B	25	15.6	2.5	12.7	12	59
Drain port	D1 to D5	1-1/16-12UN-2B	41	29.2	3.3	12.7	15	170

Metric thread type (Code : 3)

	Symbol	(1)	(2)	(3)	(4)	(5)	(6)	Tightening torque (Nm)
Gauge port	a, b	M14×1.5	25	15.8	2.4	12.5	15	47
Drain port	D1 to D5	M27×2	40	29.4	3.1	12.7	15	180

Parallel piping thread type (Code : 4)

	Symbol	(1)	(2)	(3)	(4)	(5)	(6)	Tightening torque (Nm)
Gauge port	a, b	G 1/4	25	15.6	2.5	15	15	36
Pilot port	Pi	G 1/4	25	15.6	2.5	14	15	36
Drain port	D1 to D5	G 1/2	34	22.6	2.5	12.7	15	108

Flange port

Port thread type code	d1	A	B	D	Tightening torque (Nm)
1	7/16-14UNC-2B	27.8	57.2	25	98
2, 3, 4	M12	27.8	57.2	25	98

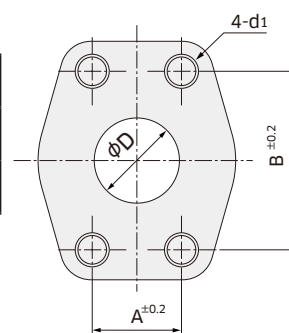

◆ Shaft End (Ordering Code [6])

ANSI B92.1a
(1-3/4in 13T 8/16DP)

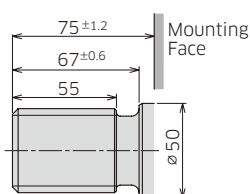

Code : 2

DIN 5480
(W40x2x18x9g)

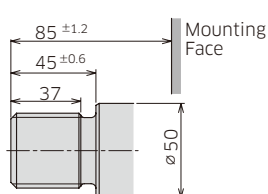

Code : 6

DIN 5480
(W45x2x21x9g)

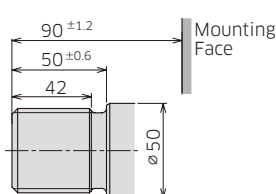

Code : 7

4. Dimensions

4-3 M7V160 Installation Dimensions

◆ M7V160 SAE Mounting, Flange Ports at Side

Model Code : M7V 160 A B 1 2 - * * 1 H1 X X X N - * *

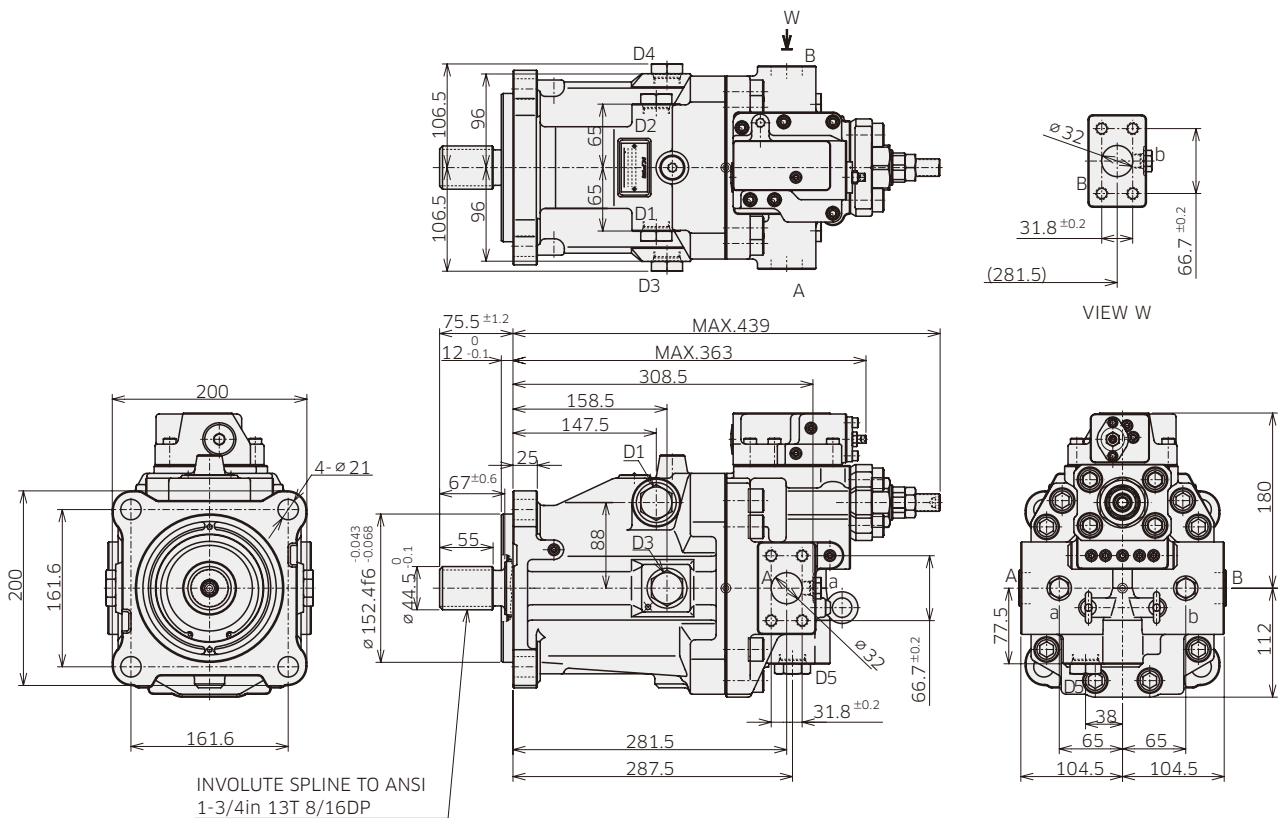

◆ M7V160 SAE Rear Port

Model Code : M7V 160 A A 1 2 - * * 1 H1 X X X N - * *

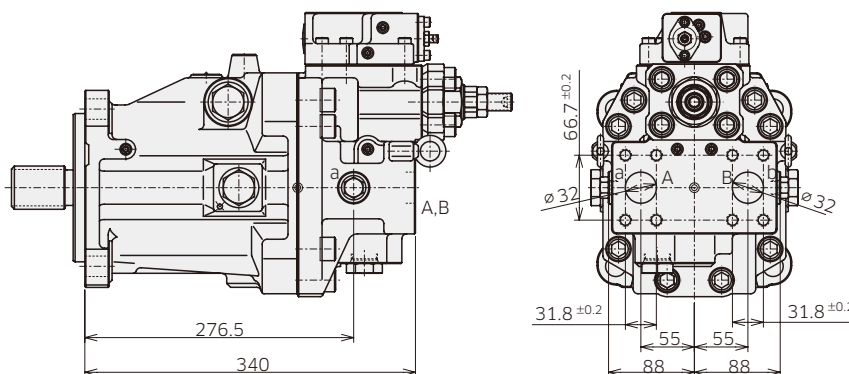

Refer to the page 40 for dimensions with other regulator options.

4. Dimensions

4-3 M7V160 Installation Dimensions

* Dimensions in mm.

◆ M7V160 ISO Mounting, Flange Ports at Side

Model Code : M7V 160 A D 4 7 - * * 1 H1 X X X N - * *

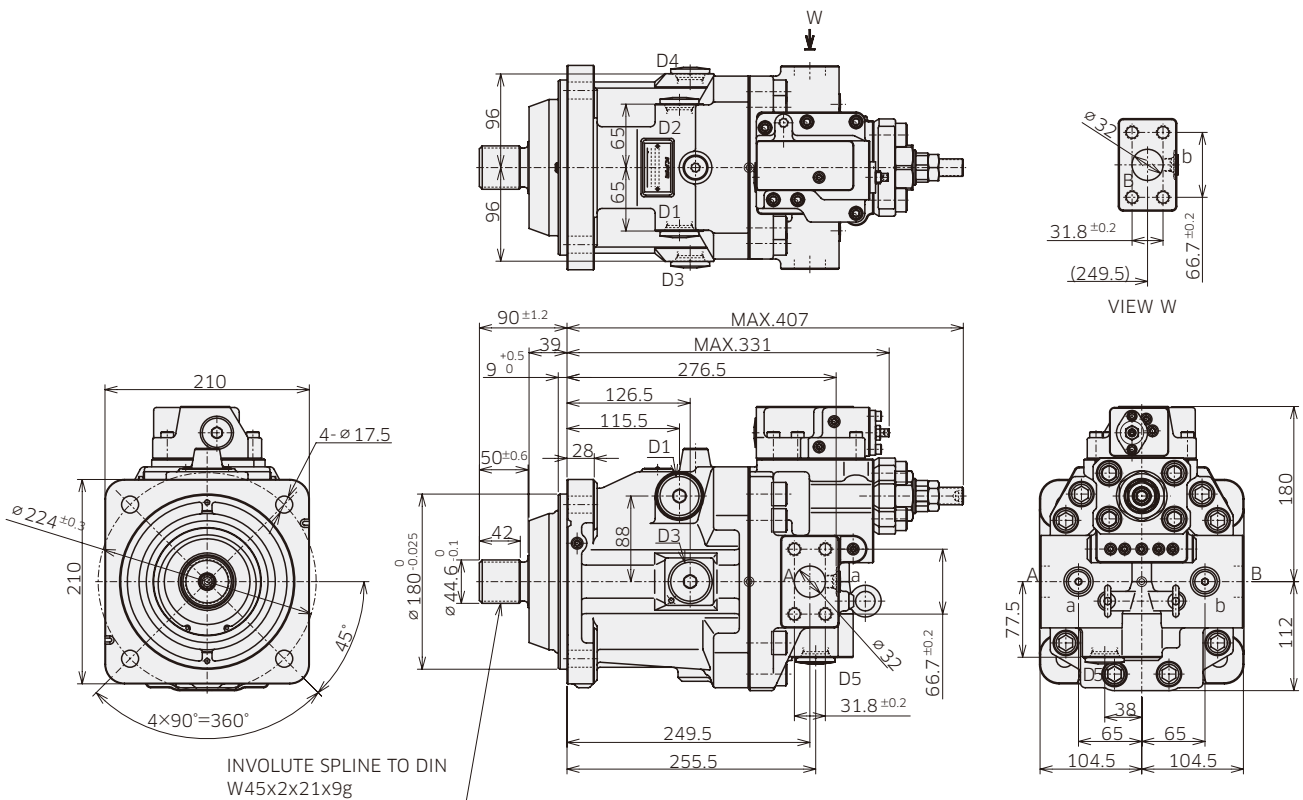

◆ M7V160 ISO Rear Port

Model Code : M7V 160 A C 4 7 - * * 1 H1 X X X N - * *

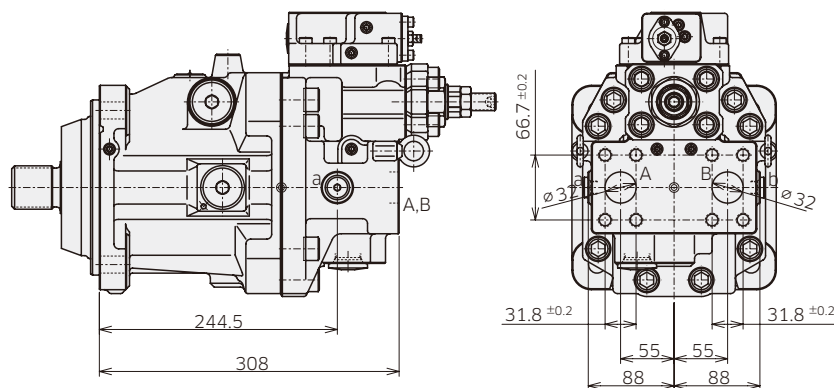

Refer to the page 40 for dimensions with other regulator options.

4. Dimensions

4-3 M7V160

◆ Port Size (Ordering Code [5]) Thread Port

ANSI thread type (Code : 1,2)

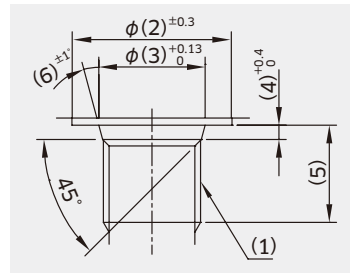

* Dimensions in mm.

	Symbol	(1)	(2)	(3)	(4)	(5)	(6)	Tightening torque (Nm)
Gauge port	a, b	9/16-18UNF-2B	25	15.6	2.5	12.7	12	59
Pilot port	Pi	9/16-18UNF-2B	25	15.6	2.5	12.7	12	59
Drain port	D1 to D5	1-1/16-12UN-2B	41	29.2	3.3	16.7	15	170

Metric thread type (Code : 3)

	Symbol	(1)	(2)	(3)	(4)	(5)	(6)	Tightening torque (Nm)
Gauge port	a, b	M14×1.5	25	15.8	2.4	12.5	15	47
Drain port	D1 to D5	M27×2	40	29.4	3.1	16.7	15	180

Parallel piping thread type (Code : 4)

	Symbol	(1)	(2)	(3)	(4)	(5)	(6)	Tightening torque (Nm)
Gauge port	a, b	G 1/4	25	15.6	2.5	15	15	36
Pilot port	Pi	G 1/4	25	15.6	2.5	14	15	36
Drain port	D1 to D5	G 3/4	45	30.8	3.5	16.7	15	170

Flange port

Port thread type code	d1	A	B	D	Tightening torque (Nm)
1	1/2-13UNC-2B	31.8	66.7	32	160
2, 3, 4	M14	31.8	66.7	32	160

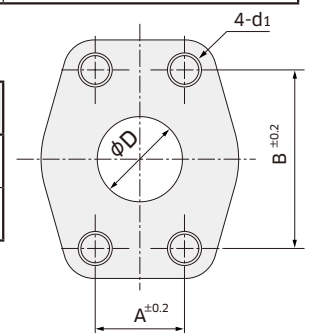

◆ Shaft End (Ordering Code [6])

ANSI B92.1a
(1-3/4in 13T 8/16DP)

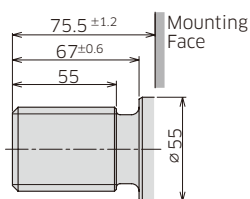

Code : 2

ANSI B92.1a
(2in 15T 8/16DP)

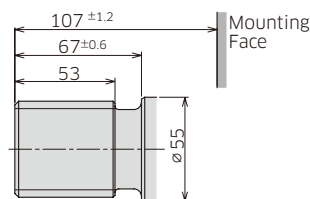

Code : 3*

DIN 5480
(W45x2x21x9g)

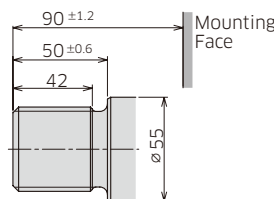

Code : 7

DIN 5480
(W50x2x24x9g)

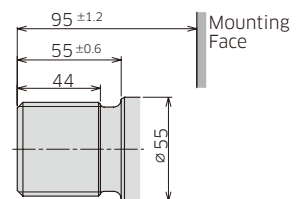

Code : 8

*Code 3 is under development.

4. Dimensions

4-4 Regulators Installation Dimensions

◆ Electric Two Position Displacement Control Regulator Code: T1, T2

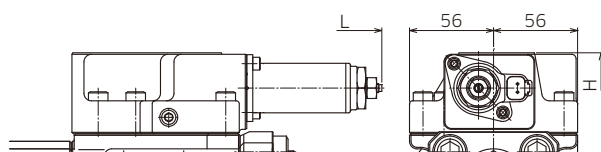

Dimension L : Length from mounting face.
Dimension H : Height from shaft center.

Dimension L, H (mm)

Motor size	Mounting type	Dimension	
		L	H
85	SAE	390	159
	ISO	366	
112	SAE	406	164
	ISO	374	
160	SAE	433	180
	ISO	401	

◆ Electric Proportional Control Regulator Code: E1, E2, E3 and E4

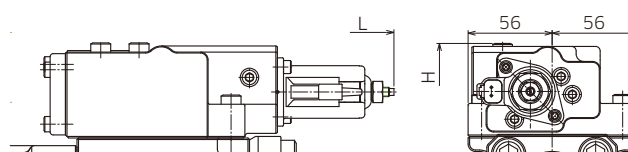

Dimension L : Length from mounting face.
Dimension H : Height from shaft center.

Dimension L, H (mm)

Motor size	Mounting type	Dimension	
		L	H
85	SAE	392	167
	ISO	368	
112	SAE	408	172
	ISO	376	
160	SAE	435	188
	ISO	403	

◆ Pressure Related Control (with Pressure Increase) Regulator Code: H2

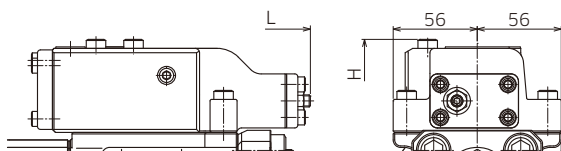

Dimension L : Length from mounting face.
Dimension H : Height from shaft center.

Dimension L, H (mm)

Motor size	Mounting type	Dimension	
		L	H
85	SAE	348	167
	ISO	324	
112	SAE	364	172
	ISO	332	
160	SAE	391	188
	ISO	359	

◆ Pressure Related Control (with Pressure Increase Hydraulic Remote Control) Regulator Code: H3

◆ Hydraulic Proportional Control Regulator Code: P1, P2, P3 and P4

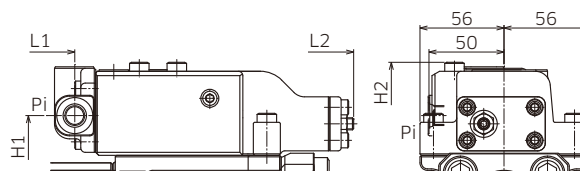

Dimension L : Length from mounting face.
Dimension H : Height from shaft center.

Dimension L, H (mm)

Motor size	Mounting type	Dimension			
		L1	L2	H1	H2
85	SAE	158	348	132	167
	ISO	134	324		
112	SAE	174	364	137	172
	ISO	142	332		
160	SAE	201	391	153	188
	ISO	169	359		

For detailed dimensions of regulators with an add-on valve, please contact Kawasaki.

Please fill the table to specify the requirements.
Please contact us for any questions.



M7V Series Inquiry Form

Please fill in the line, or tick the box inside the bold frame.
Options with ★ are under development.

Date: _____ Machine Model: _____
Application: _____
Customer Name: _____

Variable Displacement Motor

Model Code	1 M7V	2	3 A	4	5	6	7	8	9	10	11	12 X	13	14 N	15
------------	----------	---	--------	---	---	---	---	---	---	----	----	---------	----	---------	----

Items		Model Code No.	Requirements		Kawasaki feed back		
Size		2	85 <input type="checkbox"/> 112 <input type="checkbox"/> 160 <input type="checkbox"/>				
Series Specifications		3	A : Standard				
Mounting Flange and Port Position		4	Mounting		Port Position		
			A : SAE J744, 4-bolt Mount	Rear		<input type="checkbox"/>	
			B : SAE J744, 4-bolt Mount	Side		<input type="checkbox"/>	
			C : ISO 3019-2, 4-bolt Mount	Rear		<input type="checkbox"/>	
Port and Flange Fixing Thread		5	Threaded Port Type		Flange Fixing Thread Type		
			1 : ANSI ISO11926	ANSI ASMEB1.1		<input type="checkbox"/>	
			2 : ANSI ISO11926	Metric ISO724		<input type="checkbox"/> ★	
			3 : Metric ISO6149	Metric ISO724		<input type="checkbox"/> ★	
Shaft End		6	Standard		Specification		
			1 : ANSI B92.1	1 1/2 in 17T 12/24DP (for M7V85)		<input type="checkbox"/>	
			2 : ANSI B92.1	1 3/4 in 13T 8/16DP (for M7V112/160)		<input type="checkbox"/>	
			3 : ANSI B92.1	2 in 15T 8/16DP (for M7V160)		<input type="checkbox"/> ★	
			5 : DIN 5480	W35×2×16×9g (for M7V85)		<input type="checkbox"/>	
			6 : DIN 5480	W40×2×18×9g (for M7V85/112)		<input type="checkbox"/>	
			7 : DIN 5480	W45×2×21×9g (for M7V112/160)		<input type="checkbox"/>	
			8 : DIN 5480	W50×2×24×9g (for M7V160)		<input type="checkbox"/>	
			9 : ANSI B92.1	1 1/4 in 14T 12/24DP (for M7V85)		<input type="checkbox"/>	
Displacement (cm ³)	q.max (a)	7	Size	85	A : 85 <input type="checkbox"/> B : 80 <input type="checkbox"/> C : 75 <input type="checkbox"/> D : 70 <input type="checkbox"/>		
				112	A : 112 <input type="checkbox"/> B : 107 <input type="checkbox"/> C : 100 <input type="checkbox"/> D : 95 <input type="checkbox"/>		
				160	A : 160 <input type="checkbox"/> B : 155 <input type="checkbox"/> C : 150 <input type="checkbox"/> D : 140 <input type="checkbox"/>		
	q.min (b)	8	Size	85	A : 51 <input type="checkbox"/> B : 40 <input type="checkbox"/> C : 30 <input type="checkbox"/> D : - E : -		
				112	A : 68 <input type="checkbox"/> B : 50 <input type="checkbox"/> C : 40 <input type="checkbox"/> D : 30 <input type="checkbox"/> E : 22 <input type="checkbox"/>		
				160	A : 96 <input type="checkbox"/> B : 80 <input type="checkbox"/> C : 60 <input type="checkbox"/> D : 40 <input type="checkbox"/> E : 32 <input type="checkbox"/>		
Pressure	Nominal				MPa		
	Max.				MPa		
Flow	Nominal		(c)	L/min	Speed	Disp. Max (c)/(a) × 1000 =	min ⁻¹
						Disp. Min (c)/(b) × 1000 =	min ⁻¹
	Max.		(d)	L/min	Speed	Disp. Max (d)/(a) × 1000 =	min ⁻¹
						Disp. Min (d)/(b) × 1000 =	min ⁻¹
Speed Sensor		9	1 : Without Speed Sensor <input type="checkbox"/> 2 : With Speed Sensor <input type="checkbox"/> ★				
Regulator (For Control options with optional valves see the table for M7V Control Options shown below.)		10	T	Two Position Displacement Control	T1 : Electric Control, 24V	<input type="checkbox"/>	
					T2 : Electric Control, 12V	<input type="checkbox"/>	
			E	Electric Proportional Control	E1 : Negative Control, 24V	<input type="checkbox"/>	
					E2 : Positive Control, 24V	<input type="checkbox"/>	
					E3 : Negative Control, 12V	<input type="checkbox"/>	
					E4 : Positive Control, 12V	<input type="checkbox"/>	
			P	Hydraulic Proportional Control	P1 : Negative Control, Pi = 2.5 MPa	<input type="checkbox"/>	
					P2 : Positive Control, Pi = 2.5 MPa	<input type="checkbox"/>	
					P3 : Negative Control, Pi = 1.0 MPa	<input type="checkbox"/>	
					P4 : Positive Control, Pi = 1.0 MPa	<input type="checkbox"/>	
			H	Pressure Related Control	H1 : Without Pressure Increase	<input type="checkbox"/>	
					H2 : With Pressure Increase	<input type="checkbox"/>	
H3 : With Pressure Increase and Hydraulic Remote Control	<input type="checkbox"/>						
Optional Valves (For Control options with regulator see the table for M7V Control Options shown below.)		11	X : Without Any Optional Valve		<input type="checkbox"/>		
			Pressure Control Valve * For regulator code E, P	A1 : With a Pressure Control Valve		<input type="checkbox"/>	
				Electric Two-Position Control Valve * For regulator code H	B1 : With Electric Two-position Control Valve, 24V		<input type="checkbox"/>
			B2 : With Electric Two-position Control Valve, 12V		<input type="checkbox"/>		
Accessories		12	X : Without Any Accessory				
Counter Balance Valve		13	X : Without Counter Balance Valve		<input type="checkbox"/>		
			1 : With Counter Balance Valve Hoist at CW rotation (A port inlet)		<input type="checkbox"/> ★		
			2 : With Counter Balance Valve Hoist at CCW rotation (B port inlet)		<input type="checkbox"/> ★		
Response Speed of Control		14	N : Standard				
Design Code		15	* * : 01~				
Max. Speed					min ⁻¹		
Hydraulic Fluid ISO Grade, Brand							
Oil Temperature Range			~		°C		
Oil Viscosity Range			~		mm ² /s (cSt)		

Comments (Other requirements)	Operating condition, Duty cycle etc. (Describe your detail)
-------------------------------	---

Request Volume	Request Delivery Date	Note
----------------	-----------------------	------

M7X Series

Fixed Displacement Type Axial Piston Motor

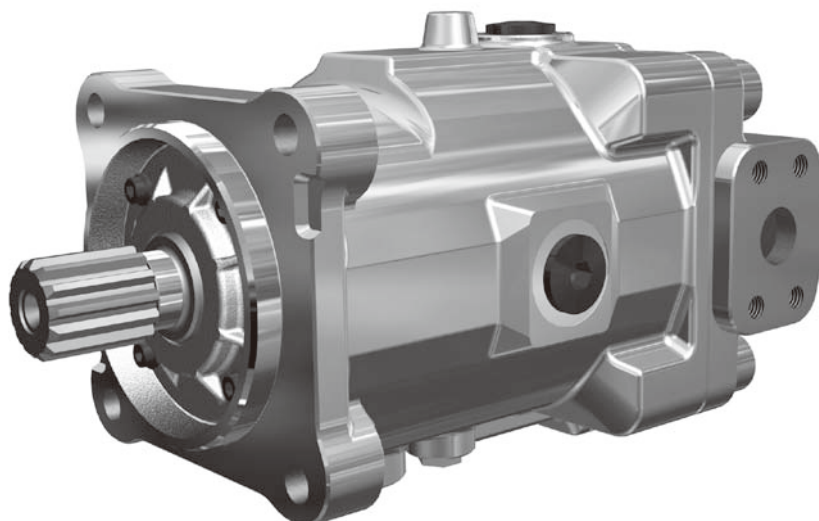

■ Specifications

Size : 85, 112, 160*

Nominal Pressure : 40 MPa (5,800 psi)

Maximum Pressure : 45 MPa (6,500 psi)

■ General Descriptions

- Applicable to an open circuit and closed circuit.
- Applicable to construction machinery and industrial vehicles.
- Swash plate design allows for a compact motor.
- High power density.

■ Features

High speed operation and smooth starting characteristics

Optimized rotary balance design enables high-speed performance and excellent starting characteristics.

Low speed operation

Superior performance in low speed operation provides excellent controllability.

Compact size

Swash plate configuration enables the motor to be much more compact.

Long bearing life

Swash plate configuration results in longer bearing life.

(*) means under development

5

M7X Ordering Code

Please fill the Inquiry Form on page 48 in order to specify the requirement.

Model Code **M7X 85 A A 1 2 - A 3 B 1 - ***

1. M7X Series

M7X Series, Fixed Displacement, Axial Piston Motor, Applicable in Both Open and Closed Loops

2. Size

	85	112	160
Standard Size	●	●	○

3. Series Specifications

A	Standard
---	----------

4. Mounting Flange and Port Position

	Mounting	Port Position	85	112	160
A	SAE J744, 4-bolt Mount	Rear	○	○	○
B	SAE J744, 4-bolt Mount	Side	●	○	○
C	ISO3019-2, 4-bolt Mount	Rear	○	○	○
D	ISO3019-2, 4-bolt Mount	Side	○	○	○
G	SAE J744, 4-bolt Mount	Upper Side	○	○	○
H	ISO3019-2, 4-bolt Mount	Upper Side	○	○	○

5. Port and Flange Fixing Thread

	Threaded Port Type	Flange Fixing Thread Type	85	112	160
1	ANSI ISO11926	ANSI ASMEB1.1	●	●	○
2	ANSI ISO11926	Metric ISO724	○	○	○
3	Metric ISO6149	Metric ISO724	○	○	○
4	Parallel piping ISO228	Metric ISO724	●	●	○

6. Shaft End

			85	112	160
1	ANSI B92.1	1 1/2 in 17T 12/24DP	○	-	○
2	ANSI B92.1	1 3/4 in 13T 8/16DP	○	●	○
3	ANSI B92.1	2 in 15T 8/16DP	○	○	○
4	ANSI B92.1	1 3/8 in 21T 16/32DP	●	-	-
5	DIN5480	W35x2x16x9 g	○	-	○
6	DIN5480	W40x2x18x9 g	○	●	○
7	DIN5480	W45x2x21x9 g	○	●	○
8	DIN5480	W50x2x24x9 g	○	○	○
9	ANSI B92.1	1 1/4 in 14T 12/24DP	●	-	-

7. Displacement Set

Size	85	A : 90	● B : 80	● C : 75	○ D : 85	●
	112	A : 112	● B : -	- C : -	- D : -	-
	160	A : -	- B : -	- C : -	- D : -	-

8. Optional Valve

		85	112	160
Blank	Without Any Optional Valve	●	●	○
1	With Counter Balance Valve Hoist at CW rotation (A port inlet)	○	○	○
2	With Counter Balance Valve Hoist at CCW rotation (B port inlet)	○	○	○
3	Flushing Valve	○	○	○

9. Port Option for Loop Flushing Valve Assembly

		85	112	160
Blank	Without Any Accessory	●	●	○
A	Parallel Piping ISO228	●	○	○
B	ANSI ISO11926	●	○	○

10. Speed Sensor

		85	112	160
1	Without Speed Sensor	●	●	○
2	With Speed Sensor	○	○	○

11. Design Code

		85	112	160
**	01~	●	●	○

● : Available
○ : Under development

6 Technical Information

6-1 Specifications

M7X Series

Size		85	112	160 *1
Max. Displacement : q_{max}	cm ³ (in ³)	90 (5.5)	112 (6.9)	160 (9.8)
Max. Speed : N_{nom}	min ⁻¹ (rpm)	4,500	3,550	3,100
Nominal pressure : P_{nom} *2	MPa (psi)	40 (5,800)	40 (5,800)	40 (5,800)
Max. Pressure : P_{max} *3	MPa (psi)	45 (6,500)	45 (6,500)	45 (6,500)
Theoretical output torque	Nm (lbf ft)	573 (423)	713 (526)	1,019 (752)
Power	kW (hp)	270 (362)	265 (355)	331 (444)
Max. Flow : Q	L/min (gallon/min)	405 (107)	398 (105)	496 (131)
Moment of inertia	kg·m ²	0.011	0.015	0.027
Volume in the case	L (gallon)	0.5 (0.21)	0.5 (0.21)	1.2 (0.32)
Mass	kg (lb)	26	34	—
Temperature	°C (°F)	-20 to +115 (-4 to +239) at drain port -20 to +90 (-4 to +194) at inlet port		
Coating		Red synthetic resin primer		

* 1 : Size 160 is under development.

* 2 : Nominal pressure corresponds to the design pressure to provide appropriate performance, function, and service life.

: Nominal pressure corresponds to the design pressure at which the products will function properly.

* 3 : Summation of pressure on A and B port shall be 56 MPa or less.

6. Technical Information

6-2 Precautions for System Design

◆ Min. Boost Pressure

To prevent cavitation when the motor is operating in a pumping mode, a positive pressure is required at the suction port.

The figure on the right shows the minimum boost pressure requirement based on regular operation. In case of a rapid change of the flow, more boost pressure must be applied.

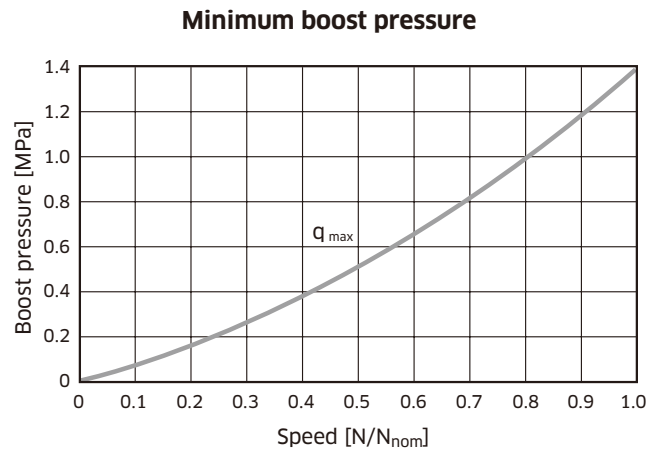

7 Dimensions

M7X112 Installation Dimensions

*Dimensions in mm.

◆ M7X112 SAE Mounting, Side Port

Model Code : M7X 112 A C 1 2 - A X X - **

D1 to D4 : Drain port 1-1/16 12UN-2B

a, b : Gauge port 9/16-18UNF-2B

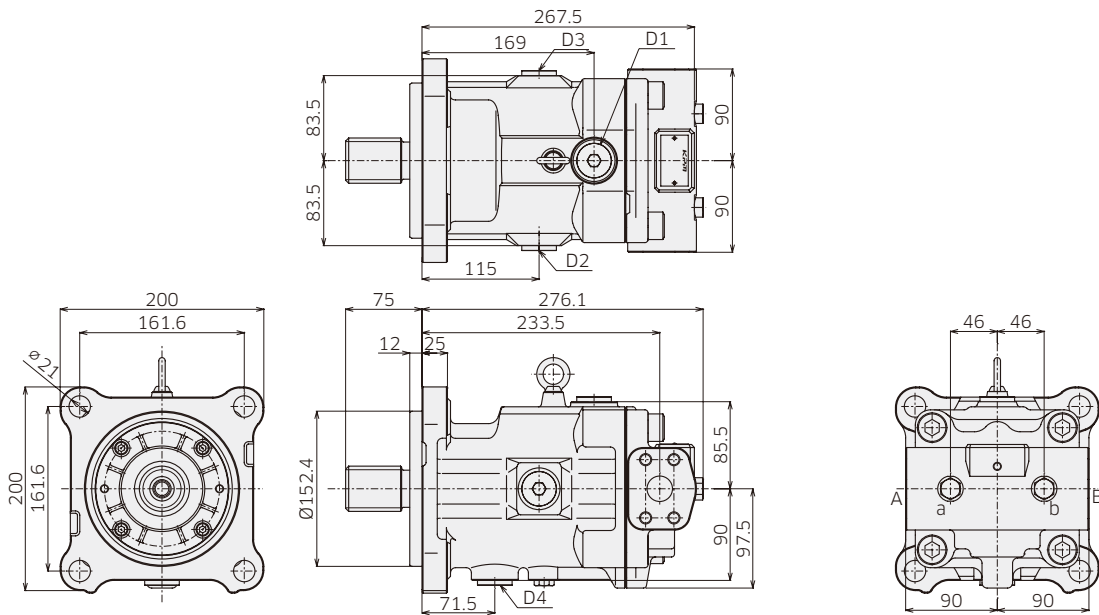

◆ M7X112 ISO Mounting, Side Port

Model Code : M7X 112 A G 4 2 - A X X - **

D1 to D4 : Drain port G1/2

a, b : Gauge port G1/4

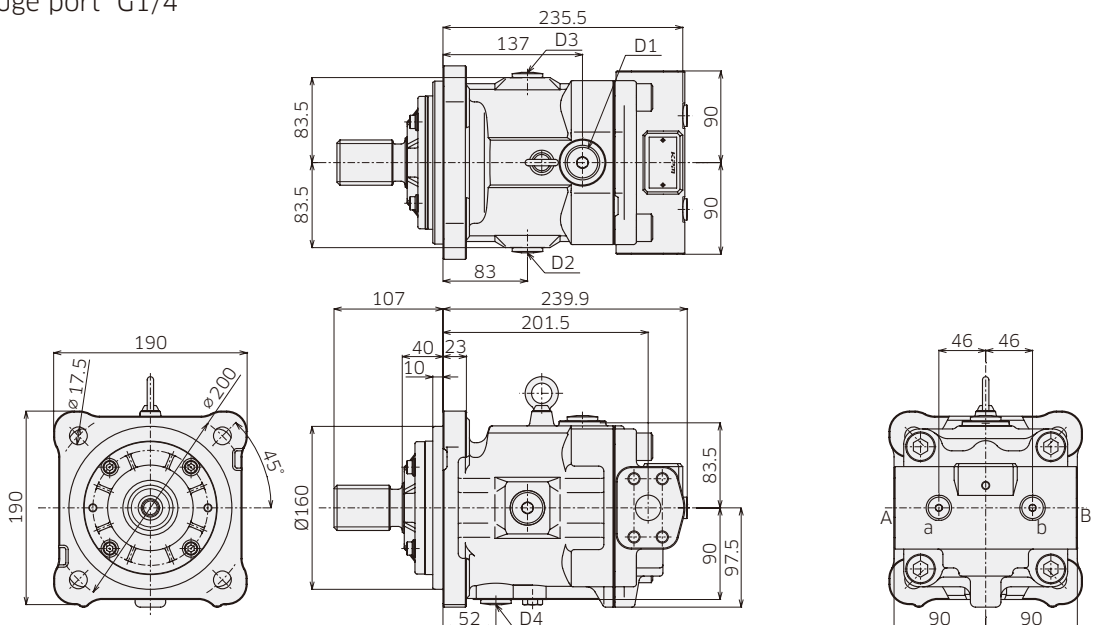

7. Dimensions

M7X112

* Dimensions in mm.

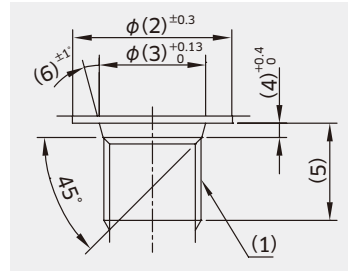

◆ M7X112 Drain and Gauge Port

ANSI thread type (Code : 1,2)

	symbol	(1)	(2)	(3)	(4)	(5)	(6)	Tightening torque (Nm)
Gauge port	a, b	9/16-18UNF-2B	25	15.6	2.5	15.5	12	59
Drain port	D1 to D4	1-1/16-12UN-2B	41	29.2	3.3	19	15	170

Metric thread type (Code : 3)

	symbol	(1)	(2)	(3)	(4)	(5)	(6)	Tightening torque (Nm)
Gauge port	a, b	M14×1.5	25	15.8	2.4	11.5	15	47
Drain port	D1 to D4	M27×2	40	29.4	3.1	19	15	180

Parallel piping thread type (Code : 4)

	symbol	(1)	(2)	(3)	(4)	(5)	(6)	Tightening torque (Nm)
Gauge port	a, b	G 1/4	25	15.6	2.5	15	15	36
Drain port	D1 to D4	G 1/2	34	22.6	2.5	12.5	15	108

Flange port

Port thread type code	d1	A	B	D	Tightening torque (Nm)
1	7/16-14UNC-2B	27.8	57.2	25	98
2, 3, 4	M12	27.8	57.2	25	98

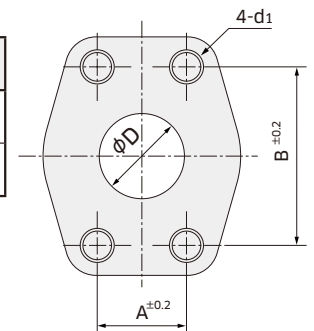

◆ M7X112 Shaft End

ANSI B92.1a
(1-3/4in 13T 8-16DP)

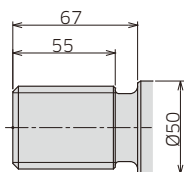

Code : 2

DIN 5480
(W40x2x18x9g)

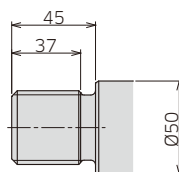

Code : 6

DIN 5480
(W45x2x21x9g)

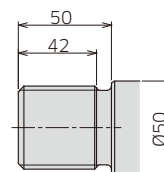

Code : 7

Please fill the table to specify the requirements.
Please contact us for any questions.

M7X Series Inquiry Form



Please fill in the line, or tick the box inside the bold frame.
Options with ★ are under development.

Date: _____ Machine Model: _____
 Application: _____
 Customer Name: _____

Variable Displacement Motor

Model Code	1	2	3	4	5	6		7	8	9	10		11
	M7X		A				-					-	

Items	Model Code No.	Requirements		Kawasaki feed back	
Size	2	85 <input type="checkbox"/> 112 <input type="checkbox"/> 160 <input checked="" type="checkbox"/> ★			
Series Specifications	3	A : Standard			
Mounting Flange and Port Position	4	Mounting Flange			
		Port Position			
		A : SAE J744, 4-bolt Mount	Rear	<input type="checkbox"/> ★	
		B : SAE J744, 4-bolt Mount	Side	<input type="checkbox"/>	
		C : ISO 3019-2, 4-bolt Mount	Rear	<input type="checkbox"/> ★	
		D : ISO 3019-2, 4-bolt Mount	Side	<input type="checkbox"/> ★	
Port and Flange Fixing Thread	5	Type of Threaded Port			
		Thread Type for Flange Port			
		1 : ANSI ISO11926	ANSI ASMEB1.1	<input type="checkbox"/>	
		2 : ANSI ISO11926	Metric ISO724	<input type="checkbox"/> ★	
Shaft End	6	Standard			
		Specification			
		1 : ANSI B92.1	1 1/2 in 17T 12/24DP (for M7X85/160)	<input type="checkbox"/> ★	
		2 : ANSI B92.1	1 3/4 in 13T 8/16DP	<input type="checkbox"/>	
		3 : ANSI B92.1	2 in 15T 8/16DP	<input type="checkbox"/> ★	
		4 : ANSI B92.1	1 3/8 in 21T 16/32DP (for M7X85)	<input type="checkbox"/>	
		5 : DIN 5480	W35×2×16×9g (for M7X85/160)	<input type="checkbox"/> ★	
		6 : DIN 5480	W40×2×18×9g	<input type="checkbox"/>	
		7 : DIN 5480	W45×2×21×9g	<input type="checkbox"/>	
8 : DIN 5480	W50×2×24×9g	<input type="checkbox"/> ★			
9 : ANSI B92.1	1 1/4 in 14T 12/24DP (for M7X85)	<input type="checkbox"/>			
Displacement Setting (cm ³)	7	Size	85	A : 90 <input type="checkbox"/> B : 80 <input type="checkbox"/> C : 75 <input type="checkbox"/> ★ D : 85 <input type="checkbox"/>	
			112	A : 112 <input type="checkbox"/> B : - C : - D : -	
			160	A : - B : - C : - D : -	
Pressure	Nominal			MPa	
	Max.			MPa	
Flow	Nominal			L/min	
	Max.			L/min	
Optional Valve	8	Blank : Without Any Optional Valve		<input type="checkbox"/>	
		1 : With Counter Balance Valve Hoist at CW rotation (A port inlet)		<input type="checkbox"/> ★	
		2 : With Counter Balance Valve Hoist at CCW rotation (B port inlet)		<input type="checkbox"/> ★	
		3 : Flushing Valve		<input type="checkbox"/> ★	
Port option for loop flushing valve assembly	9	Blank : Without Any Accessory		<input type="checkbox"/>	
		A : Parallel Piping ISO228		<input type="checkbox"/>	
		B : ANSI ISO11926		<input type="checkbox"/>	
Speed Sensor	10	1 : Without Speed Sensor		<input type="checkbox"/>	
		2 : With Speed Sensor		<input type="checkbox"/> ★	
Design Code	11	* * : 01~			
Max. Speed				min ⁻¹	
Hydraulic Fluid ISO Grade, Brand					
Oil Temperature Range		~		°C	
Oil Viscosity Range		~		mm ² /s (cSt)	

Comments (Other requirements)	Operating condition, Duty cycle etc. (Describe your detail)
-------------------------------	---

Request Volume	Request Delivery Date	Note
----------------	-----------------------	------

Kawasaki Heavy Industries, Ltd.

Precision Machinery Company

<http://www.khi.co.jp/kpm/>

Tokyo Head Office

1-14-5 Kaigan, Minato-ku, Tokyo 105-8315, Japan
Phone +81-3-3435-6862 Fax. +81-3-3435-2023

Kobe Head Office

Kobe Crystal Tower, 1-3 Higashikawasaki-cho 1-chome, Chuo-ku, Kobe 650-8680, Japan
Phone +81-78-360-8607 Fax. +81-78-360-8609

Nishi-kobe Works

234, Matsumoto, Hasetani-cho, Nishi-ku, Kobe 651-2239, Japan
Phone +81-78-991-1160 Fax. +81-78-991-3186

OVERSEAS SUBSIDIARIES

Kawasaki Precision Machinery (UK) Ltd.

Ernesettle Lane, Ernesettle, Plymouth, Devon, PL5 2SA United Kingdom
Phone +44-1752-364394 Fax. +44-1752-364816
<http://www.kpm-eu.com>

Kawasaki Precision Machinery (U.S.A.), Inc.

3838 Broadmoor Avenue S.E. Grand Rapids, Michigan 49512, U.S.A.
Phone +1-616-975-3100 Fax. +1-616-975-3103
<http://www.kpm-usa.com>

Kawasaki Precision Machinery (Suzhou) Ltd.

668 JianLin Rd, New District, Suzhou, 215151 China
Phone +86-512-6616-0365 Fax. +86-512-6616-0366

Kawasaki Precision Machinery Trading (Shanghai) Co., Ltd.

17th Floor (Room 1701), The Headquarters Building, No168, XiZang Road (M), Huangpu District, Shanghai, 200001, China
Phone +86-21-3366-3800 Fax. +86-21-3366-3808

Kawasaki Chunhui Precision Machinery (Zhejiang) Ltd.

No.200 Yasha Road Shangyu Economic Development Zone, Shansyu, Zhejiang, 312300, China
Phone +86-575-8215-6999 Fax. +86-575-8215-8699

Flutek, Ltd.

98 GIL 6, Gongdan-Ro, Seongsan-Ku, Changwon-Si, Kyungnam, 51567, Korea
Phone +82-55-210-5900 Fax. +82-55-286-5557

Wipro Kawasaki Precision Machinery Private Limited

No. 15, Sy. No. 35 & 37, Kumbalgodu Industrial Area, Kumbalgodu Village, Kengeri Hobli, Bangalore, - 560074 ,India



QR code
Precision Machinery
Company Website