

DRAWING No. 016506			
ISSUE	CHANGE	DATE	CHK.
A		06.09	
B		01.12	FS

DO NOT SCALE

IF IN DOUBT-ASK

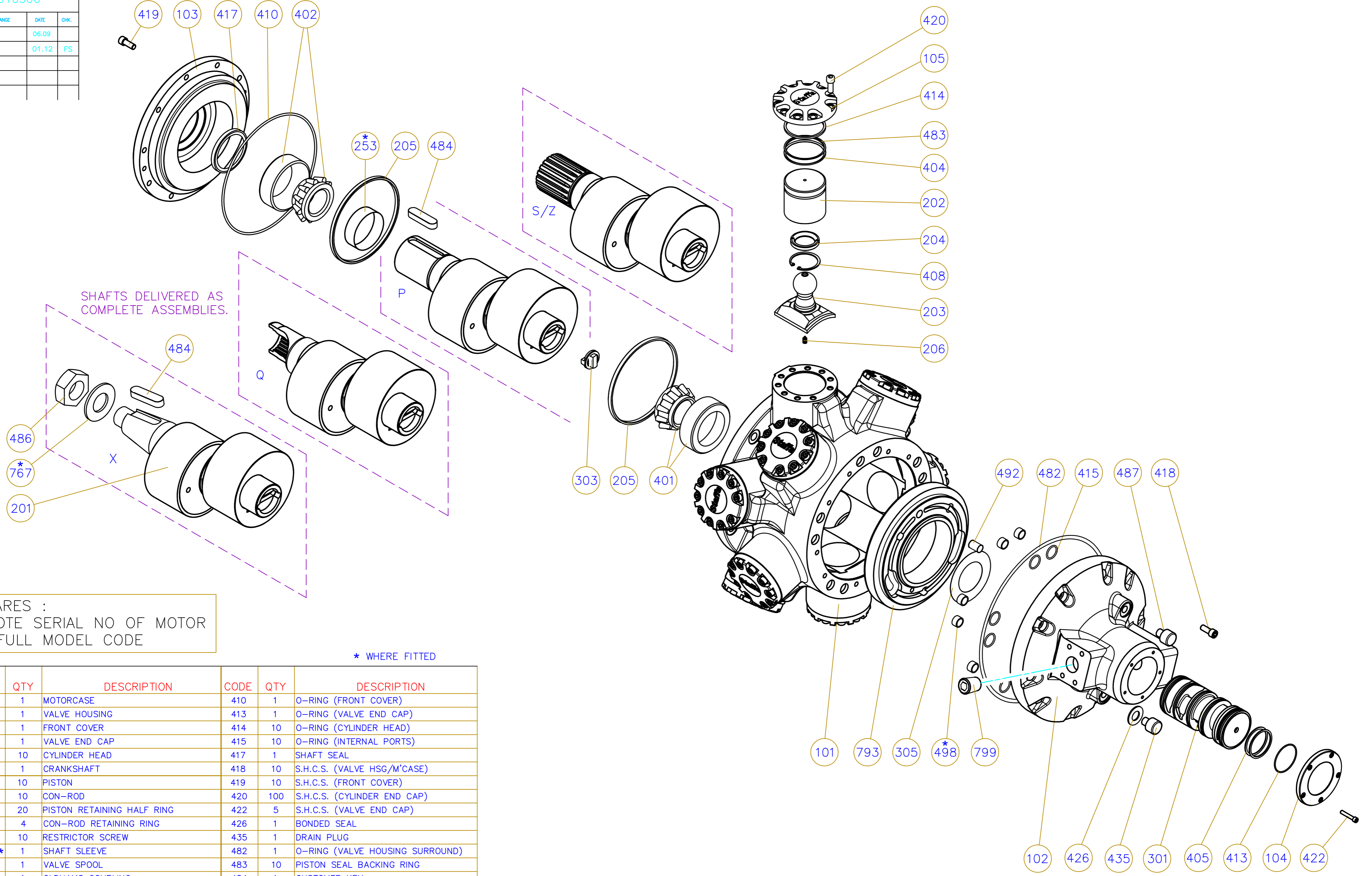

SPARES :
QUOTE SERIAL NO OF MOTOR
+ FULL MODEL CODE

* WHERE FITTED

CODE	QTY	DESCRIPTION	CODE	QTY	DESCRIPTION
101	1	MOTORCASE	410	1	O-RING (FRONT COVER)
102	1	VALVE HOUSING	413	1	O-RING (VALVE END CAP)
103	1	FRONT COVER	414	10	O-RING (CYLINDER HEAD)
104	1	VALVE END CAP	415	10	O-RING (INTERNAL PORTS)
105	10	CYLINDER HEAD	417	1	SHAFT SEAL
201	1	CRANKSHAFT	418	10	S.H.C.S. (VALVE HSG/M'CASE)
202	10	PISTON	419	10	S.H.C.S. (FRONT COVER)
203	10	CON-ROD	420	100	S.H.C.S. (CYLINDER END CAP)
204	20	PISTON RETAINING HALF RING	422	5	S.H.C.S. (VALVE END CAP)
205	4	CON-ROD RETAINING RING	426	1	BONDED SEAL
206	10	RESTRICTOR SCREW	435	1	DRAIN PLUG
253 *	1	SHAFT SLEEVE	482	1	O-RING (VALVE HOUSING SURROUND)
301	1	VALVE SPOOL	483	10	PISTON SEAL BACKING RING
303	1	OLDHAMS COUPLING	484	1	CUSTOMER KEY
305	-	SHIM (STEEL)	486	1	SHAFT NUT
401	1	REAR BEARING	487	1	PLASTIC PLUG
402	1	FRONT BEARING	492	1	DOWEL
404	10	PISTON SEAL RING	498 *	7	O-RING RETAINER
405	12	VALVE SEAL RING	767 *	1	KEEP PLATE
408	10	CIRCLIP (PISTON-INTERNAL)	793	1	INNER BEARING HOUSING
			799	1	TAPER PLUG

THIRD ANGLE PROJECTION 	DR.	M.NORMAN	DATE	08.06.09	 Ernescliffe, Plymouth PL5 2SA www.kpm-eu.com
	CHK.				
	ENGRS. APPL.				
	WT.				
TITLE GENERAL ASSEMBLY (FOR SPARES) HMHDB400 MOTOR					
ALL TECHNICAL DATA DISCLOSED HEREIN IS THE PROPERTY OF KAWASAKI AND SHALL NOT BE USED BY OTHERS FOR MANUFACTURE, PROCUREMENT, OR DISCLOSURE WITHOUT THE WRITTEN PERMISSION OF THE OWNER.					
SIZE	A1	SCALE	NTS	DRAWING No.	016506
SIMILAR TO-				SHEET	1 of 1